

TECHNICAL NOTE

# Pump Cart Instruction Manual

June 2023

*J. Eidam*

*for the Vacuum group*

*at European XFEL*

European X-Ray Free-Electron Laser Facility GmbH

Holzoppel 4

22869 Schenefeld

Germany



---

# Contents

<b>1</b>	<b>General description</b>	<b>4</b>
1.1	Requirements	7
1.2	Preconditions for operation	7
1.3	Venting	8
1.4	Leak detection	8
<b>2</b>	<b>Pump cart display</b>	<b>9</b>
<b>3</b>	<b>Pump cart operation</b>	<b>10</b>
3.1	Start display	11
3.2	System test request	12
3.3	Performing the system test	13
3.4	Situation after the system test	14
3.5	Opening V3	15
3.6	Situation when V3 is open	16
3.7	Leak test	17
3.8	Heating mode	18
3.9	Stopping the pump cart	19
3.10	Venting the pump cart (upper part)	20
3.11	Menu	21
3.12	Venting the pump cart (bottom part)	22
3.13	Software info	23
3.14	Change limit values	24
3.15	Change limit values – Password-protected (1)	25
3.16	Change limit values – Password-protected (2)	26
3.17	Diagram	27
3.18	Diagram – change time scale	28
3.19	Diagram – Data logger (1)	29
3.20	Diagram – Data logger (2)	30
3.21	Counterflow leak test (1)	31
3.22	Counterflow leak test (2)	32
3.23	Counterflow leak test (3)	33
<b>4</b>	<b>Malfunctions and error handling</b>	<b>34</b>
4.1	No Ethernet connection	35
4.2	No compressed air	36
4.3	Turbo pump fuse error	37

4.4	Gauge fuse error .....	38
4.5	RGA fuse error .....	39
4.6	Valve error .....	40
4.7	Scroll pump has no power .....	41
4.8	Turbo pump general error .....	42
4.9	Scroll pump timer error .....	43
4.10	Turbo pump timer error .....	44
4.11	Pressure p2 too low for venting .....	45
<b>5</b>	<b>Remote operation per Ethernet .....</b>	<b>46</b>
<b>6</b>	<b>Heating .....</b>	<b>47</b>
<b>7</b>	<b>Data logger .....</b>	<b>48</b>
<b>8</b>	<b>Leak detection general description .....</b>	<b>49</b>
8.1	Using the leak detector .....	50
8.2	Checking and calibrating the leak detector .....	52
<b>9</b>	<b>Leak detector display .....</b>	<b>53</b>
9.1	Leak detector display after switching on the leak detector .....	53
9.2	Leak detector display after startup of the leak detector .....	53
9.3	Measuring mode (1) .....	54
9.4	Measuring mode (2) .....	54
9.5	Diagram mode .....	55
9.6	Filament interlock .....	55
<b>10</b>	<b>Leak detector remote control .....</b>	<b>56</b>

# 1 General description

The purpose of the XFEL pump carts is to pump vacuum chambers or beamline sections down to a vacuum of  $10^{-8}$  mbar. The pump carts have a scroll pump and a turbo pump. Accordingly, a pressure in the ultrahigh vacuum range can be achieved. Generally, this range of ultrahigh vacuum is required to switch on ion pumps, which then generate a vacuum of up to  $10^{-10}$  mbar and also keep this vacuum.

A DN40 CF angle valve is required to connect a pump cart to a vacuum chamber or a beamline section.

European XFEL pump carts are serviced by the European XFEL Vacuum group and can be borrowed from there. Make sure your vacuum component is clean and oil-free when using one of the European XFEL pump carts.

The picture shows a pump cart connected to a beamline section.

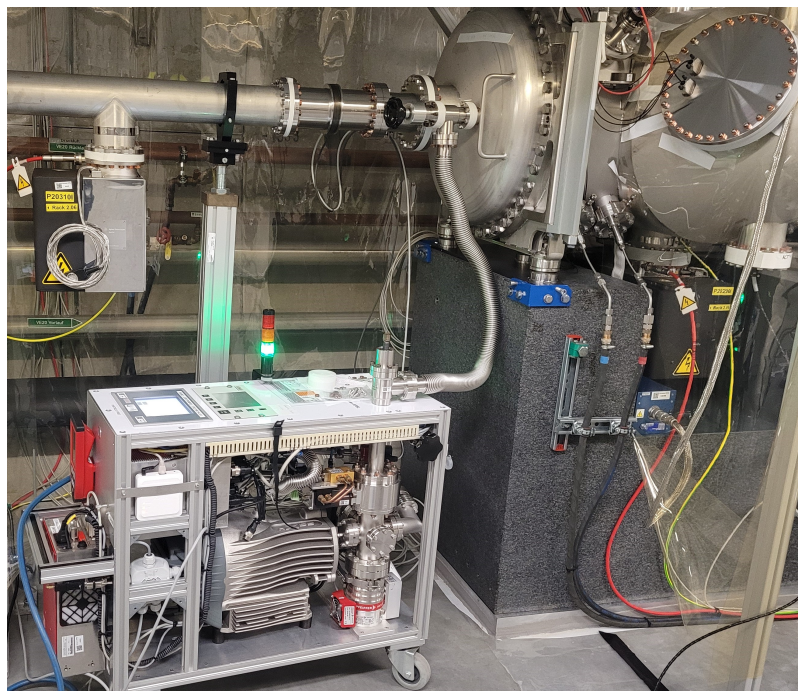



In the figures below, the pump cart is shown from both sides, so that all components can be seen.

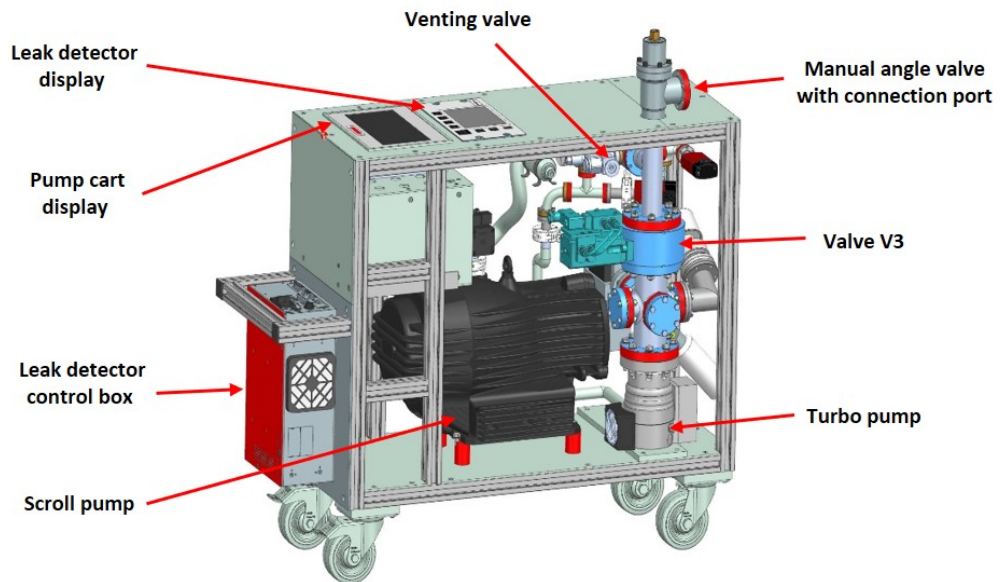
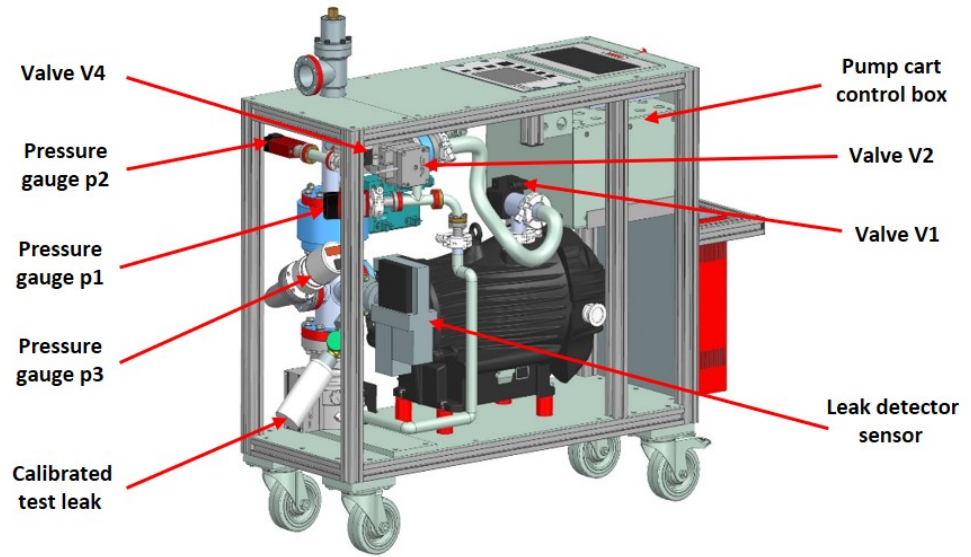

**Table 1.1:** Pump cart parts

<b>Pump cart part</b>	<b>Description</b>
Scroll pump	Vacuum pump for evacuation of the system down to $1 \times 10^{-2}$ mbar (low vacuum).
Turbo pump	Vacuum pump for evacuation of the system down to $1 \times 10^{-8}$ mbar (ultrahigh vacuum).
Valve V1	Protection valve against venting through the scroll pump.
Valve V2	Bypass valve.
Valve V3	Butterfly valve as a separation between the pump cart and the vacuum chamber.
Valve V4	Automatic venting valve for venting the turbo pump from the bottom up to slow down the rotation speed.
Venting valve	Manual venting valve for venting the pump cart above V3. Always vent with dry nitrogen!
Manual angle valve	Manual separation between the pump cart and the vacuum chamber and connection port to the vacuum chamber.
Pressure gauge p1	Pirani gauge for measuring the pressure of the achieved vacuum above the scroll pump (range to $5 \times 10^{-3}$ mbar).
Pressure gauge p2	Pirani gauge for measuring the pressure of the achieved vacuum above V3 (range to $5 \times 10^{-3}$ mbar).
Pressure gauge p3	Full range gauge for measuring the pressure of the achieved vacuum above the turbo pump (range to $5 \times 10^{-9}$ mbar).
Pump cart display	Display for operating and viewing the current status of the pump cart.
Leak detector display	<i>Optional:</i> Display for operating and viewing the current status of the leak detector.
Leak detector	<i>Optional:</i> Helium leak detector; instead or additionally a residual gas analyzer (RGA) can be connected.
Calibrated test leak	<i>Optional:</i> Test leak for testing and calibrating the leak detector.

---

## 1.1 Requirements

To operate the pump cart, the following items are required:

- Power supply 230 V 50 Hz (power consumption 800 W)
- Compressed air 5–7 bar delivered by quick coupling connector NW 7.2 mm
- DN 40 CF pumping port on the vacuum chamber to be pumped
- Dry nitrogen supply with DN 16 ISO-KF flange connection for venting

---

## 1.2 Preconditions for operation

Make sure that the pump cart is standing on a level surface before startup. Connect the flange of the pump cart to the vacuum chamber to be pumped. Insert the plug into a properly installed Schuko socket. Connect a compressed air line to the compressed air connection of the pump cart.

The pump cart main switch is located on the back side of the pump cart control box. The fuses are also placed there. The compressed air port is situated on the pump cart side.

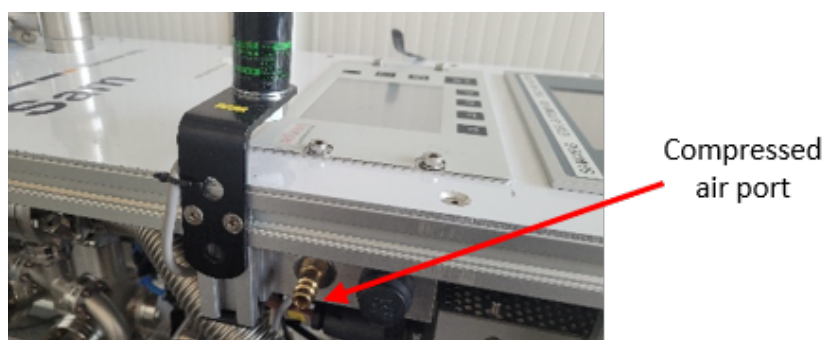
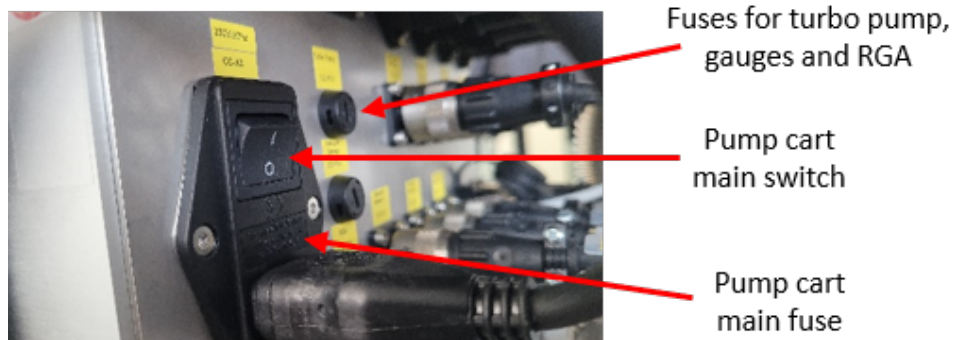

---

## 1.3 Venting

The pump cart is vented by the DN 16 ISO-KF port of the venting valve.

**NOTE:** Always vent the pump cart with dry nitrogen!

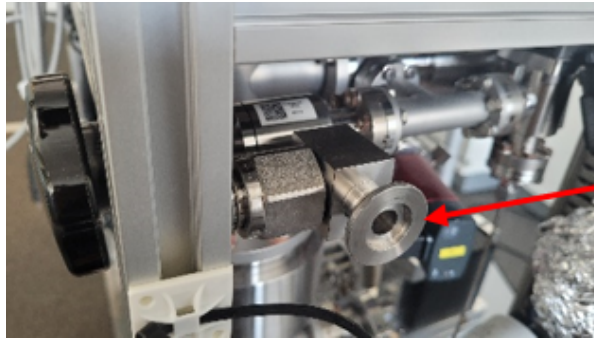

Venting  
valve port

---

## 1.4 Leak detection

The leak detector power switch is located on the red leak detector control box. Some pump carts are equipped with a leak detector remote control.

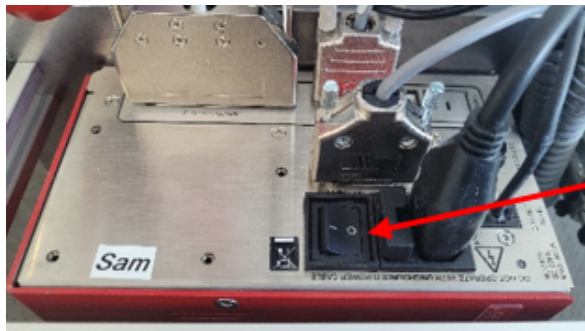

Leak detector  
power switch



Leak detector  
remote control

## 2 Pump cart display

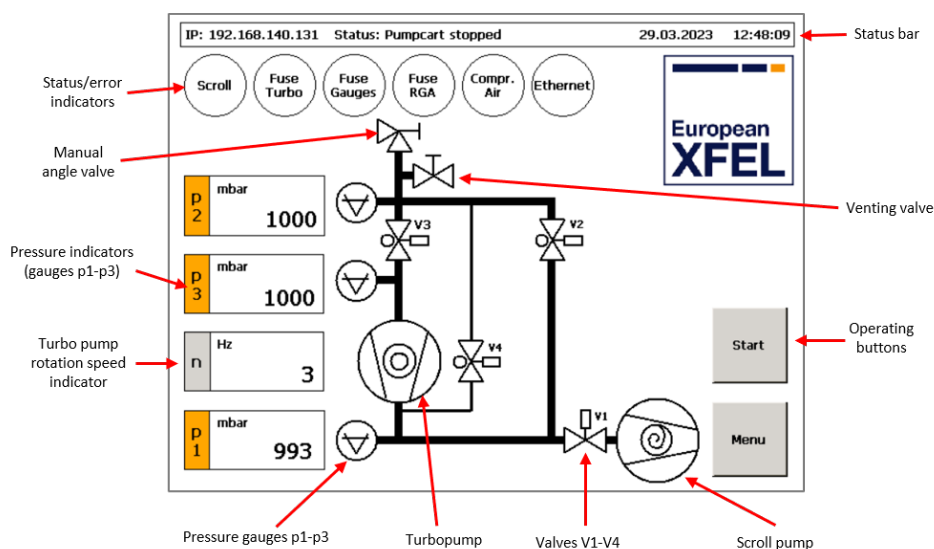

**Table 2.1:** Display description

Display part	Description
Status bar	The status bar shows the IP number of the pump cart, if there is an Ethernet connection available. In addition, it shows the current status, date, and time.
Scroll, Fuse Turbo, Fuse Gauges, Compressed Air indicators	These indicators must be OK to start the pump cart. A red indicator shows an error condition.
Fuse RGA, Ethernet indicators	These indicators are not mandatory to operate the pump cart. In case of failure, they show a grey colour.
RGA Enabled, Leakd. Enabled indicators (not shown here)	These indicators show that the pressure is low enough to switch on the leak detector or the RGA (optionally attached), respectively.
Pressure indicators p1–p3	Indicators for the pressure values of the gauges p1–p3
Turbo pump rotation speed indicator	Indicator for the turbo pump rotation speed in Hz. The final rotation speed is 1500 Hz.
Operating buttons	Different operation buttons appear, based on the status of the pump cart (see description below).

---

## 3 Pump cart operation

To start the pump cart, switch on the main switch on the back of the pump cart control box (see Section 1.2, “Preconditions for operation”). It takes a few moments for the PLC to start up.

On the left side of the status bar, the IP number is shown. Every pump cart has a fixed IP number, which is assigned to it via Wi-Fi. So if the pump cart is registered in the network, this IP number is shown here and the pump cart can be controlled via Ethernet.

0.0.0.0 → no WiFi connection available

168.XXX.XXX.XXX → there is a connection between the pump cart PLC and the WiFi bridge, but no connection to the Ethernet

192.168.140.XXX → Ethernet connection is working

To find out how to control the pump cart per Ethernet, see Chapter 5, “Remote operation per Ethernet”.

The second menu item shows the current status of the pump cart, which after switching on is always “pump cart stopped”.

The current date and time, which are updated via Ethernet, are displayed on the right side of the status bar.

## 3.1 Start display

After the pump cart is switched on through the main switch, the display looks like this.

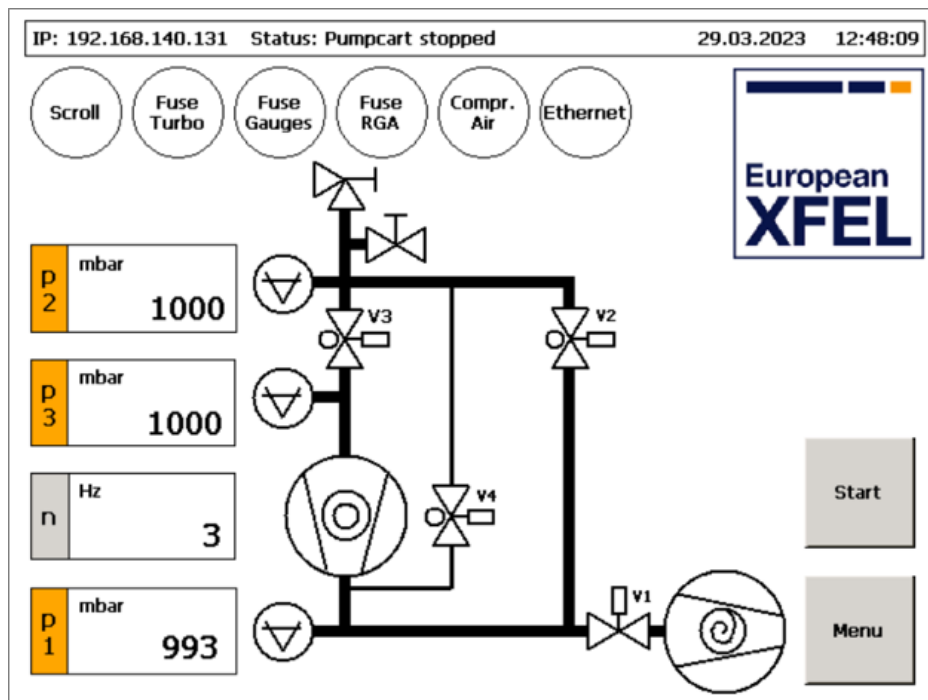

In this initial state, all valves are closed and both pumps are off.

In this case, the whole pump cart is vented, as shown by the pressure indicators.

The error indicators show that compressed air is connected and that all fuses are OK.

In case of an error, the problem is shown by the error indicators and an error message (see Chapter 4, “Malfunctions and error handling”).

The pump cart can be started now by pressing the “Start” button.

## 3.2 System test request

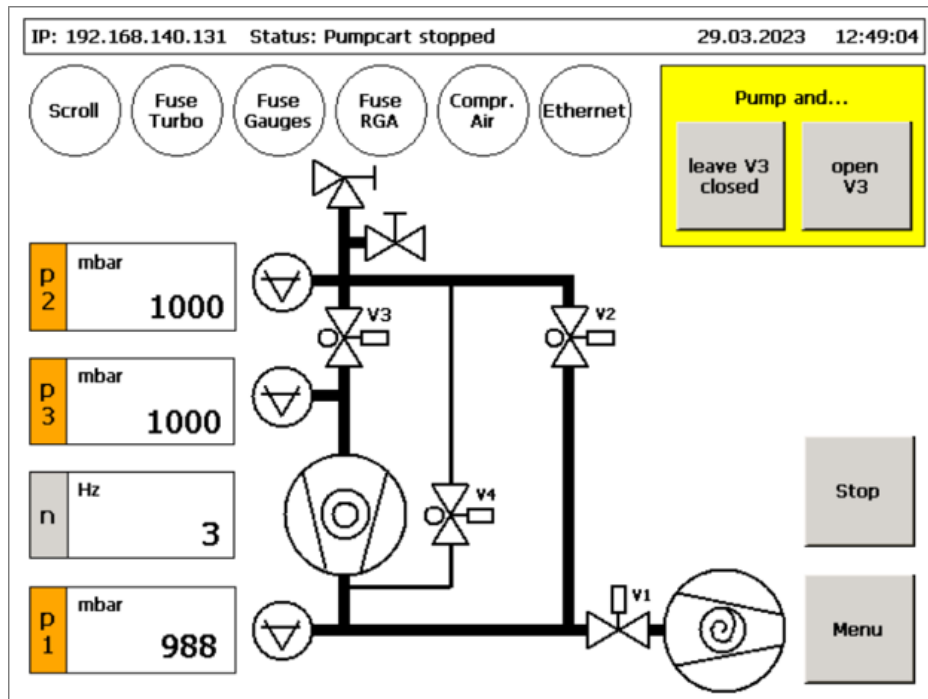

You can choose if you want to pump only the pump cart (up to V2 and V3) so both valves V2 and V3 stay closed. This option is interesting for a system test to check whether the pump cart itself is OK before pumping a connected vacuum chamber.

Parameters of pumps, such as rotation speed and achieved pressure in a certain time, will be checked.

If you already know that the pump cart is OK, you can skip the system test and press the “open V3” button. So the whole system is pumped up to the next closed valve, this can be the manual angle valve. Make sure that you have connected a closed vacuum system to the pump cart if this valve is open.

Skipping the system test will lead directly to the situation described in Section 3.6, “Situation when V3 is open”.



### 3.3 Performing the system test

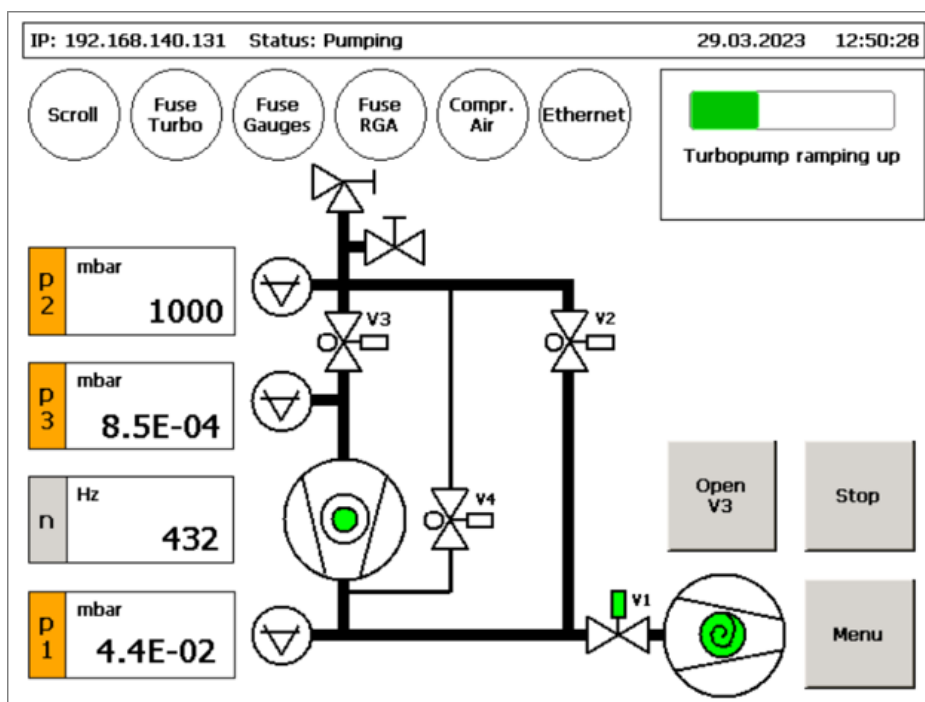

The display looks like this while the system test is executed automatically in the following order:

The scroll pump starts, this is indicated by the colour green. After a short time, valve V1 opens, also indicated in green. The pump cart is pumped up to V2 and V3 through the scroll pump. When a certain pressure level is achieved, the turbo pump starts. The rotation of the turbo pump is shown by the green blinking and the increasing rotation speed. The final rotation speed of the turbo pump is 1500 Hz.

In case of a failed system test, the pump cart stops and a window with an error message appears. (For examples, see Section 4.9, “Scroll pump timer error”, and Section 4.10, “Turbo pump timer error”.)

The system test can be skipped anytime by pressing the “Open V3” button.

## 3.4 Situation after the system test

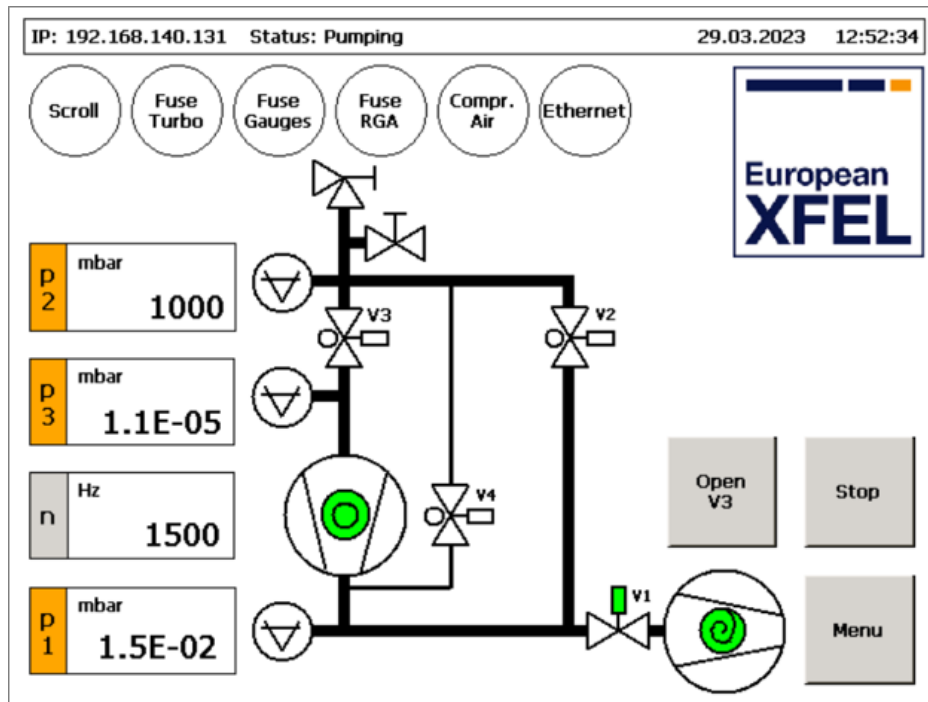

After a successful system test, you can press the “open V3” button. This valve is the only one that can be operated through the touch panel.

The electrical actuated valves V1, V2, and V4 are automatically operated by the pump cart control system.

**NOTE:** To pump a connected vacuum chamber the manual angle valve must be opened before pressing the “Open V3” button!

Pressing the “Stop” button stops the pump cart. That means that both pumps shut down and all valves close.

## 3.5 Opening V3

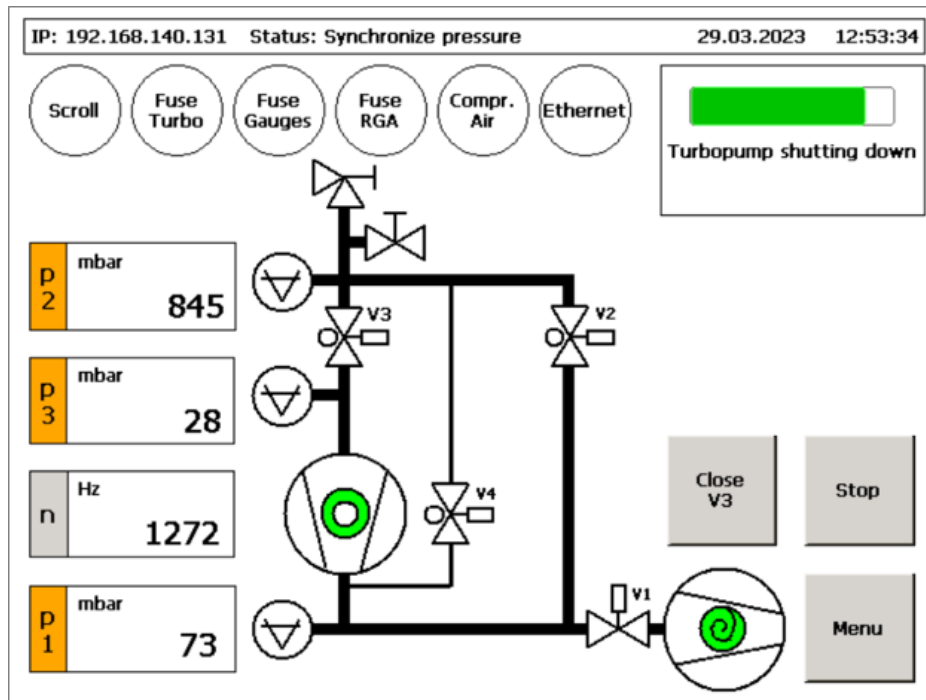

If “Open V3” is pressed, the pump cart control system checks whether it is necessary to synchronize the pressure levels of p2 and p3 before opening V3. Pressure synchronization can be necessary because of the maximum permissible differential pressure to open the valve and also to prevent shock venting of the turbo pump.

In this example, the synchronization process has to be performed because the pressure difference between p2 and p3 is too high. Besides the turbo pump must be shut down before opening V3.

The process of synchronization of the pressure levels and the shutdown of the turbo pump is operated automatically by the pump cart control system. It is executed by opening V4 several times for a short moment.

If the pressure level above V3 is already low, V3 opens immediately.

### 3.6 Situation when V3 is open

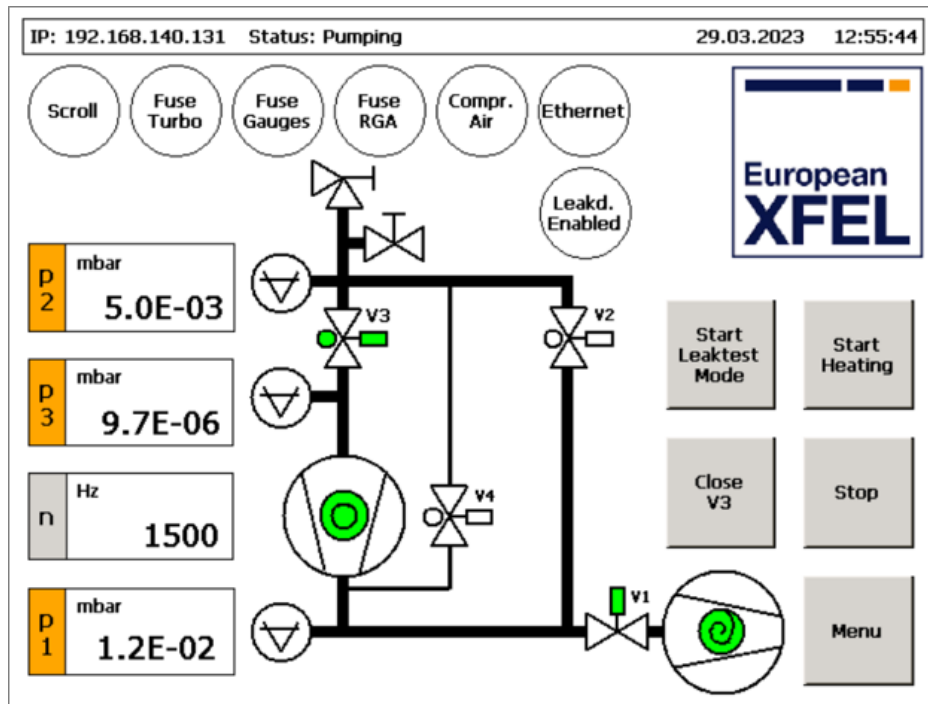

After opening V3 and some pumping time, the display looks like this.

In this status the scroll pump does not run permanently. It is switched off automatically, if pressure p1 is below a certain level.

If the pressure level is low enough to permit switching on the heating or the leak detector, the corresponding buttons appear.

If the pressure level is low enough to allow the RGA release it will be enabled. This is shown by the appearance of the “RGA enabled” indicator. If there is an RGA attached to the pump cart it can be switched on now.

## 3.7 Leak test

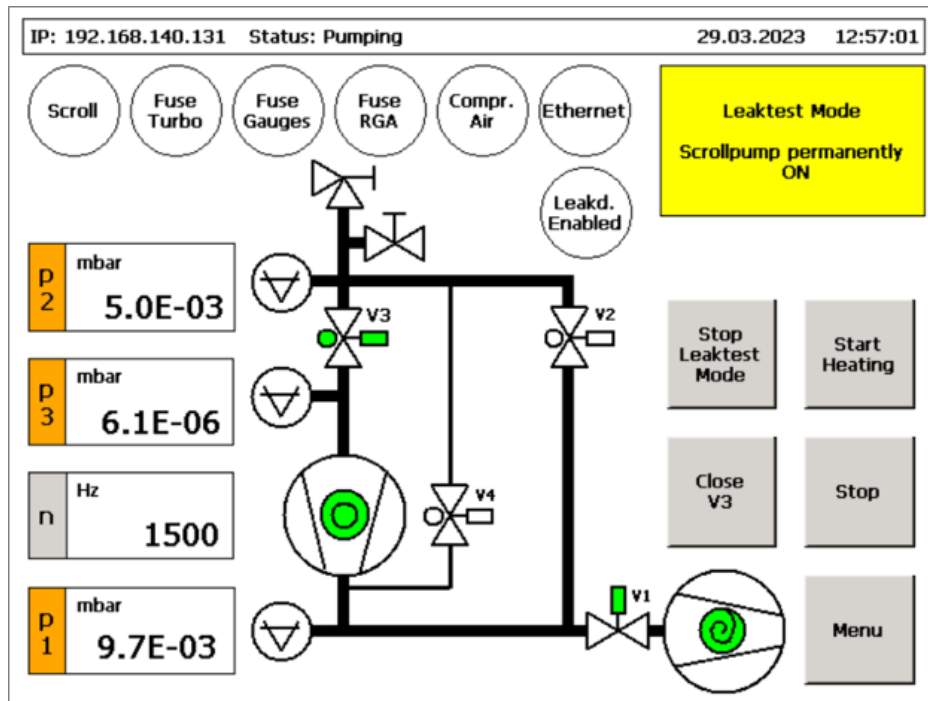

Pressing the “Start Leaktest Mode” button leads to the scroll pump permanently running.

The leak test mode should be used while performing a leak test because, if a leak is found, helium will be pumped out of the vacuum system more easily.

After pressing the button, it turns into a “Stop Leaktest Mode” button for switching off the leak test mode.

## 3.8 Heating mode

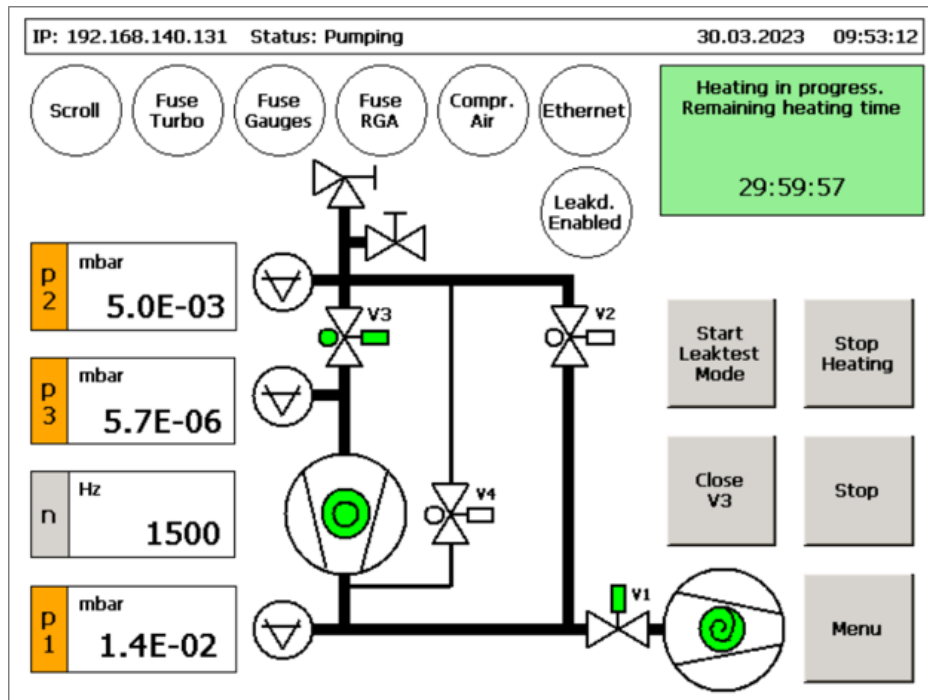

Pressing the “Start Heating” button enables the heating release output of the pump cart.

This heating release output can be connected to an external heating controller/distributor (see Chapter 6, “Heating”).

Through this option, a heating process of the vacuum system (heating time and pressure) can be controlled by the pump cart control system.

A timer appears that shows the remaining heating time; the heating time is 30 hours by default and can be changed in the menu.

While heating, the scroll pump runs permanently (as in the leak test mode).

## 3.9 Stopping the pump cart

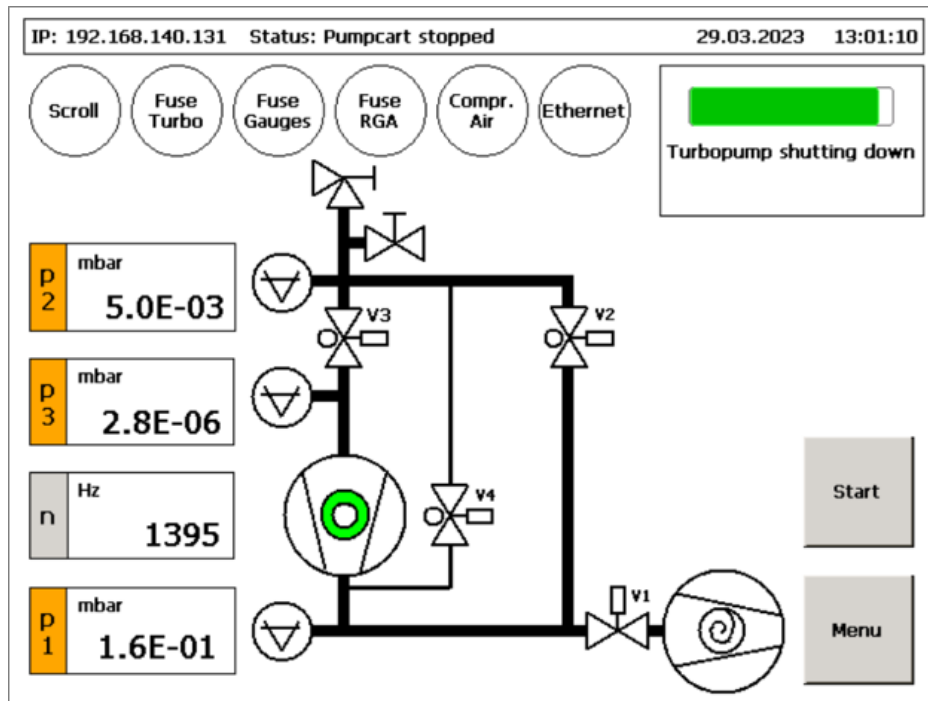

By pressing the “Stop” button, all valves close and both pumps stop.

While the turbo pump is shutting down, the pump cart should not be moved, as moving can cause a bearing failure of the pump.

**NOTE:** The shutting down process of the pump takes a few minutes. Wait until the pump is completely shut down!

## 3.10 Venting the pump cart (upper part)

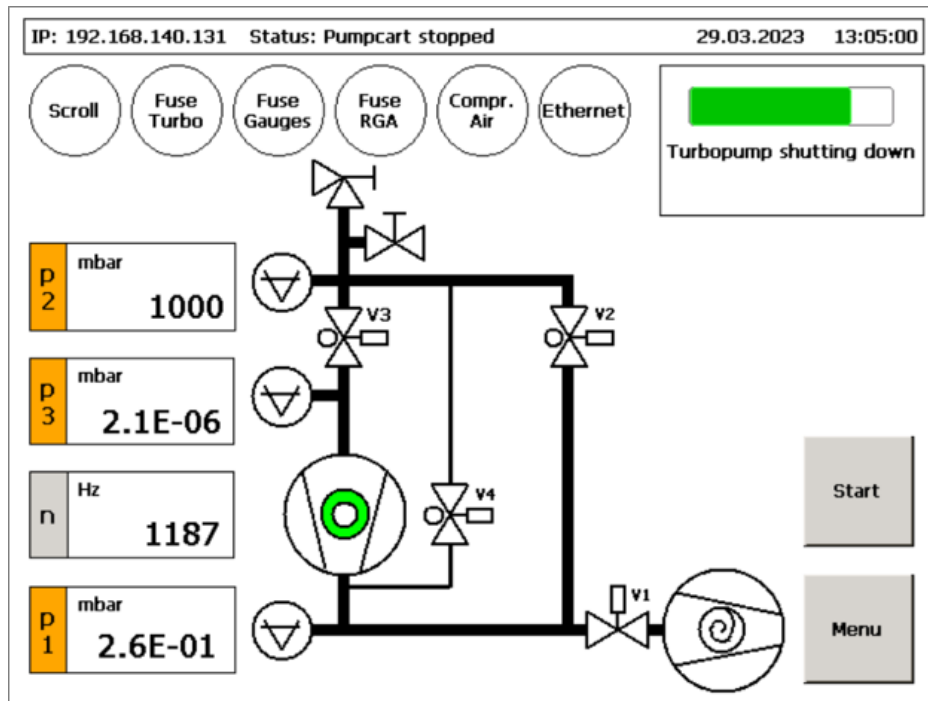

**NOTE:** V3 must be closed before venting!

This means that the “Close V3” button or the “Stop” button must be pressed before venting!

Always vent the pump cart with dry nitrogen! A dry nitrogen supply must be connected on the DN 16 ISO-KF port of the hand venting valve (see Section 1.3, “Venting”).

Now the venting valve must be opened. The upper part of the pump cart is completely vented when the pressure p<sub>2</sub> shows 1000 mbar.

**NOTE:** Do not forget to close the hand venting valve after venting!

To find out how to vent the bottom part of the pump cart, see Section 3.11, “Menu”, and Section 3.12, “Venting the pump cart (bottom part)”.



## 3.11 Menu

IP: 192.168.140.131 Status: Pumpcart stopped29.03.2023 13:03:37

Pressure and Timer Limit Values		
Scrollpump ON when p1 >	1E0 mbar	Reset
Scrollpump OFF when p1 <	8E-2 mbar	Reset
Turbopump ON when p1 <	3E0 mbar	Reset
Heating ON when p3 <	1E-5 mbar	Reset
Heating OFF when p3 >	1E-4 mbar	Reset
Heating time	1800 min	Reset
Leaktest enable when p3 <	9E-5 mbar	Reset
RGA enable when p3 <	1E-6 mbar	Reset
Scrollpump timer error when V3 open	60 min	Reset
Turbopump timer error when V3 open	60 min	Reset

**Pressure Time Diagram**

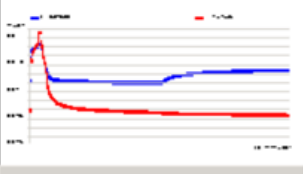

**Zoom Diagram**

Vent Pumpcart

Software Info

Change Limit Values

Back to Main

By pressing the “Menu” button, the pressure and timer limit values and the pressure vs. time diagram are shown.

The pressure vs. time diagram can be extended to full screen by pressing the “Zoom Diagram” button (see Section 3.17, “Diagram”).

The “Vent Pumpcart” button is available only if the pump cart is stopped. Pressing this button causes that the bottom part of the pump cart below V2 and V3 is vented through valve V4 (Section 3.12, “Venting the pump cart (bottom part)”).

Pressing the “Software Info” button opens a software info window (Section 3.13, “Software info”).

The “Change Limit Values” button switches to the expert mode, in which pressure and timer limit values can be changed. This mode is only accessible by password (Section 3.14, “Change limit values”).

## 3.12 Venting the pump cart (bottom part)

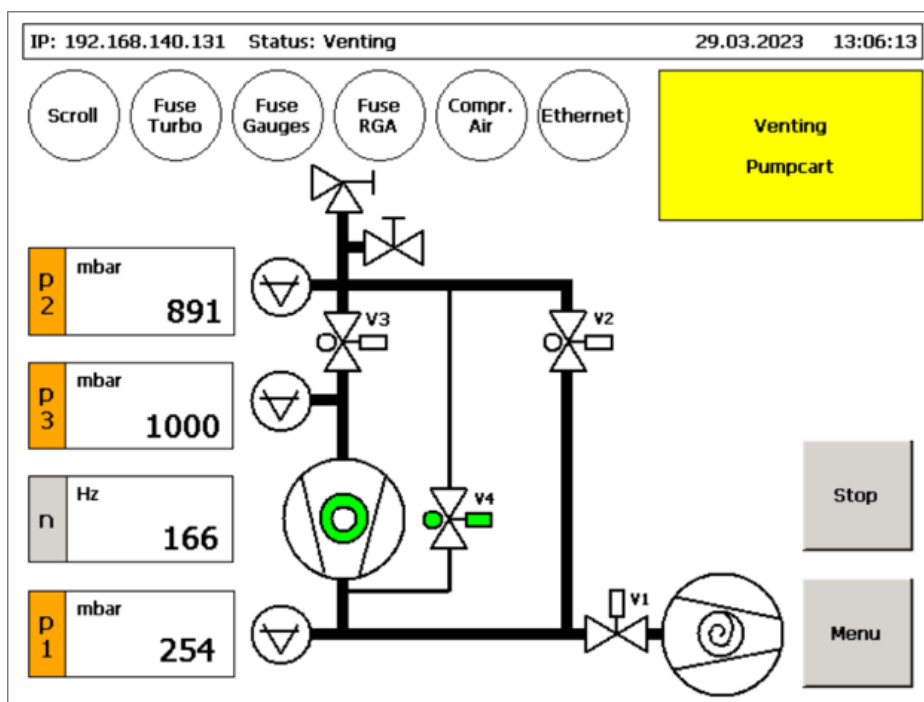

When you press the “Vent Pumpcart” button in the menu (see Section 3.11, “Menu”), the display switches back to the main window, so you can observe the venting procedure.

To vent the bottom part of the pump cart, a dry nitrogen supply must be connected to the hand venting valve and the valve must be opened. Venting of the bottom part of the pump cart accelerates the shutdown of the turbo pump. Depending on the turbo pump rotation speed, V4 will be opened several times for a short moment or even permanently until the whole pump cart is vented.

The venting process can be followed by watching the pressure indicators. In the end, p1, p2, and p3 should show 1000 mbar, and the “Venting Pumpcart” window is closed automatically. The pump cart is now back in the state described in Section 3.1, “Start display”.

**NOTE:** Do not forget to close the hand venting valve after venting!

### 3.13 Software info

IP: 192.168.140.131 Status: Pumpcart stopped 29.03.2023 13:07:48

Pressure and Timer Limit Values		
Scrollpump ON when p1 >	1E0 mbar	Reset
Scrollpump OFF when p1 <	8E-2 mbar	Reset
Turbopump ON when p1 <		
Heating ON when p3 <		
Heating OFF when p3 >		
Heating time		
Leaktest enable when p3 <	9E-5 mbar	Reset
RGA enable when p3 <	1E-6 mbar	Reset
Scrollpump timer error when V3 open	60 min	Reset
Turbopump timer error when V3 open	60 min	Reset

**European XFEL GmbH**  
Pumpcart Software  
Version 2.6  
© 2023 Janni Eidam

Pressure Time Diagram

Zoom Diagram

Vent Pumpcart

Software Info

Change Limit Values

Back to Main

If the “Software Info” button is pressed, a window opens that shows information about the current software version.

This window can be closed by pressing the “Software Info” button again or by pressing directly inside the window.

## 3.14 Change limit values

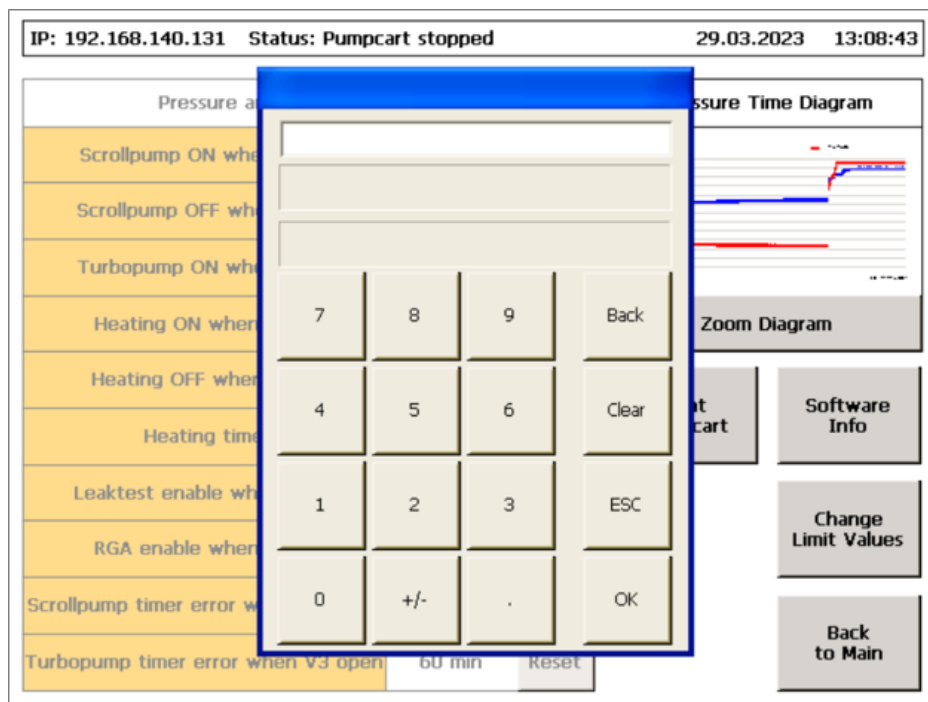

The limit values can be changed only by authorized persons and is accessible by password.

Pressing the “Change Limit Values” button opens an input window to enter the password.

### 3.15 Change limit values – Password-protected (1)

Pressure and Timer Limit Values		
Scrollpump ON when p1 >	1E0 mbar	Reset
Scrollpump OFF when p1 <	8E-2 mbar	Reset
Turbopump ON when p1 <	3E0 mbar	Reset
Heating ON when p3 <	1E-5 mbar	Reset
Heating OFF when p3 >	1E-4 mbar	Reset
Heating time	1800 min	Reset
Leaktest enable when p3 <	9E-5 mbar	Reset
RGA enable when p3 <	1E-6 mbar	Reset
Scrollpump timer error when V3 open	60 min	Reset
Turbopump timer error when V3 open	60 min	Reset

Pressure Time Diagram

Zoom Diagram

Vent Pumpcart

Software Info

Change Limit Values

Back to Main

If the correct password has been entered, the background turns yellow and the pressure and timer limit values become active.

The numbers can now be changed by touching the corresponding white fields.

Press the part of the number you want to change:

- To change the mantissa, press the mantissa.
- To change the exponent, press the exponent.

## 3.16 Change limit values – Password-protected (2)

IP: 192.168.140.131    Status: Pumpcart stopped    29.03.2023    13:11:31

Pressure and Timer Limit Values		
Scrollpump ON when p1 >	1E0 mbar	Reset
Scrollpump OFF when p1 <	8E-2 mbar	Reset
Turbopump ON when p1 <	3E0 mbar	Reset
Heating ON when p3 <	1E-5 mbar	Reset
Heating OFF when p3 >	1E-4 mbar	Reset
Heating time	3000 min	Reset
Leaktest enable when p3 <	9E-5 mbar	Reset
RGA enable when p3 <	1E-6 mbar	Reset
Scrollpump timer error when V3 open	60 min	Reset
Turbopump timer error when V3 open	60 min	Reset

**Pressure Time Diagram**



Zoom Diagram

Vent Pumpcart

Software Info

Change Limit Values

Back to Main

After a change has been entered, the background of the changed parameter is indicated in yellow.

Pressing the “Reset” button resets the changed parameter to the default value.

Exit of the password-protected section takes place automatically after 3 minutes or by pressing the “Zoom Diagram” button or the “Back to Main” button.

**CAUTION:** If the pump cart is powered off and restarted, all parameters are switched back to the default numbers.

## 3.17 Diagram

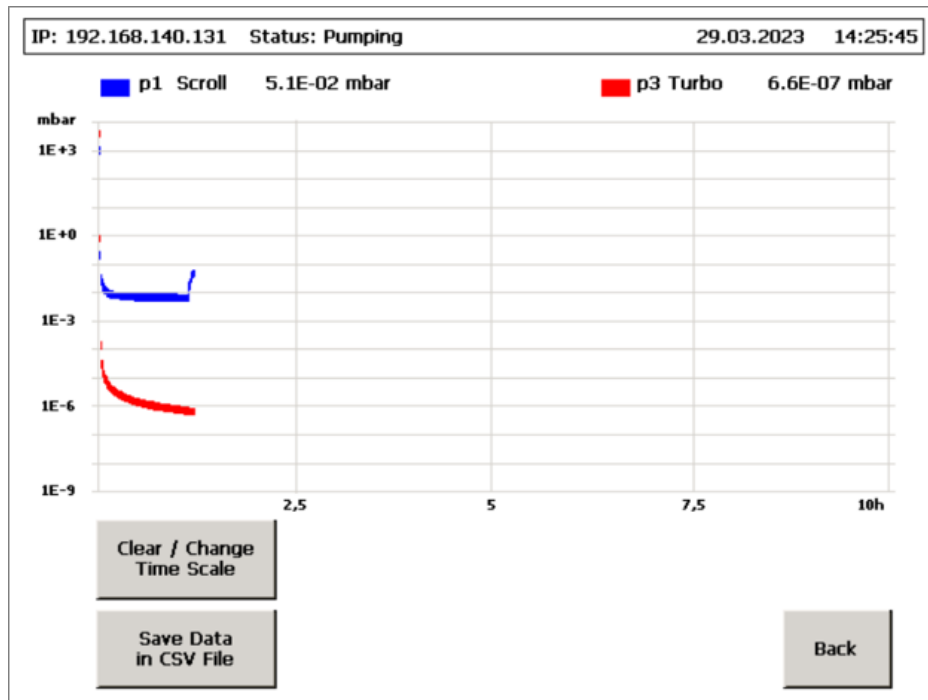

The diagram shows the history of p1 and p3 over time.

The timescale can be changed or cleared.

In addition, you can make use of the data logger option by saving the values of p1, p2, and p3 over time into a CSV file. (For details, see Section 3.19, “Diagram – Data logger (1)”, and Section 3.20, “Diagram – Data logger (2)”).

### 3.18 Diagram – change time scale

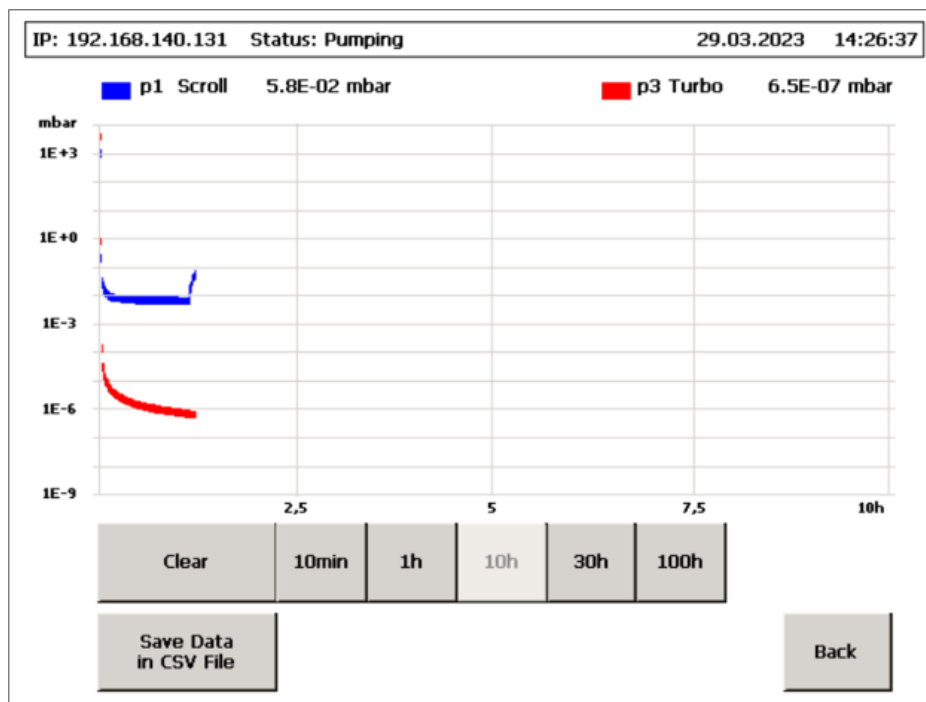

Pressing the “Clear / Change Time Scale” button opens a menu bar in which the timescale can be changed or the history cleared.

The menu bar closes automatically after 5 seconds to prevent clearing shown data by accidental pressing of buttons.



### 3.19 Diagram – Data logger (1)

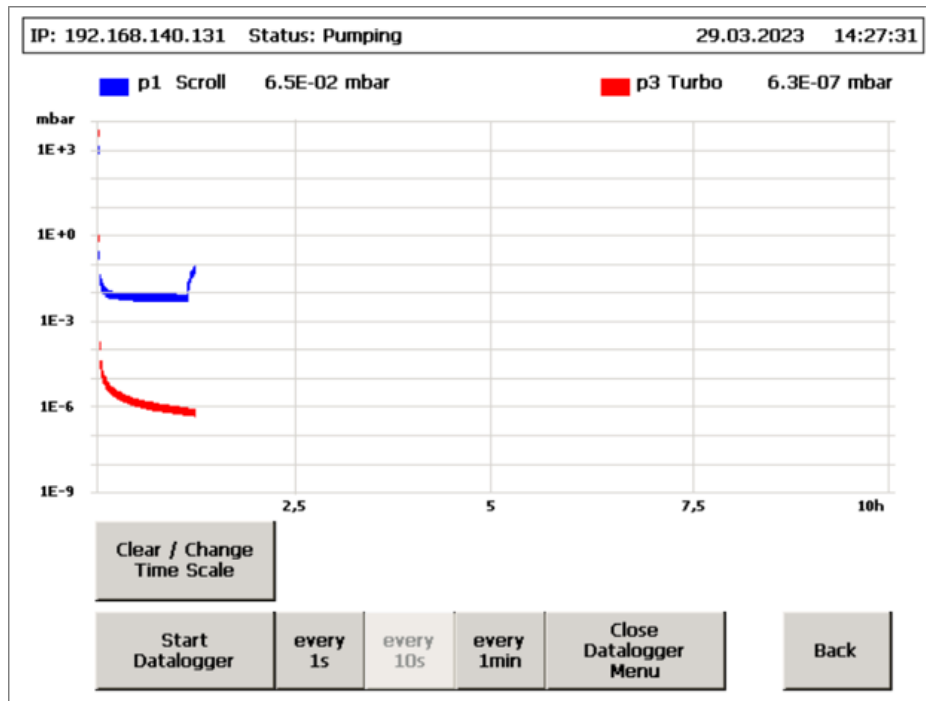

Pressure data can be saved in a CSV file. Therefore, a USB stick must be connected to the USB port in front of the pump cart (see Chapter 7, “Data logger”).

Pressing the “Save Data in CSV File” button opens a menu bar in which the time interval for the data recording can be chosen.

Pressing the “Start Datalogger” button starts the data logger automatically, and data of p1, p2, and p3 are saved in a CSV file on the connected USB stick.

## 3.20 Diagram – Data logger (2)

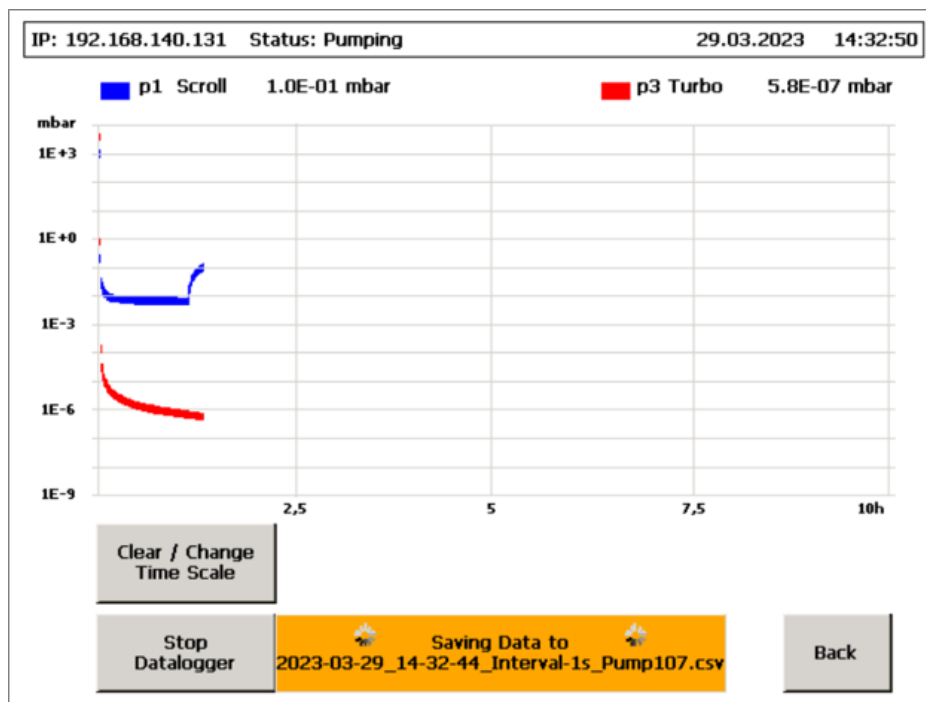

Data is stored on the USB stick.

The name of the CSV file is of this format:

yyyy-mm-dd\_hh-mm-ss\_interval\_pumpcartname

The “Stop Datalogger” button terminates the saving of data.

Starting the data logger again creates a new CSV file with the current date and time.

## 3.21 Counterflow leak test (1)

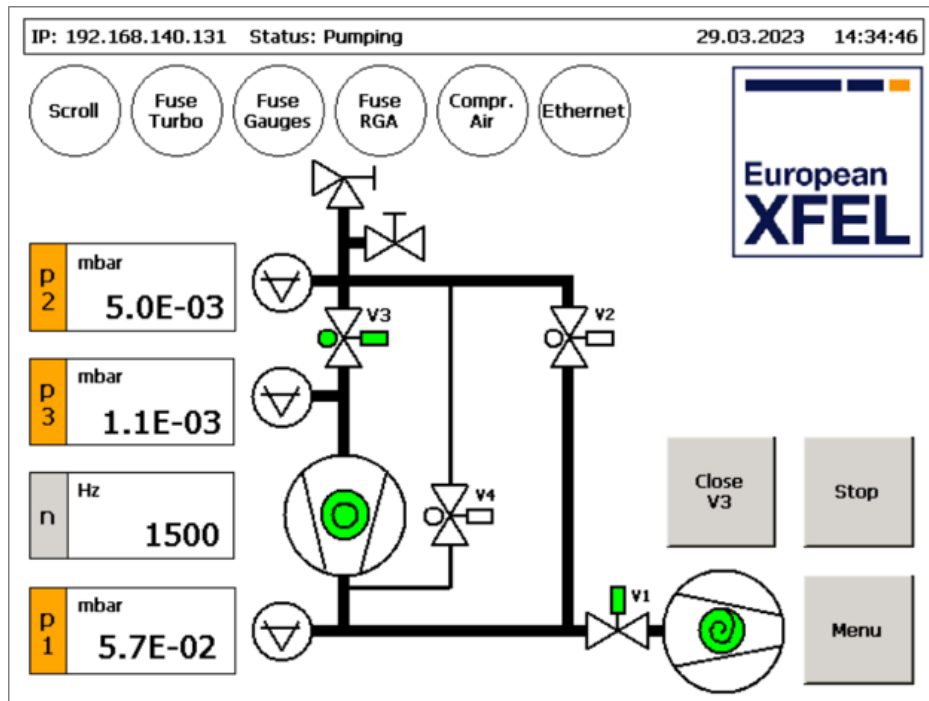

To prevent burning of the filament, the leak detector is controlled by an interlock and cannot be switched on if the pressure  $p_3$  is too high and above the release set point, as in this example.

In this case, the option of a counterflow leak test is available.

The “Counterflow Leaktest” button can be found in the menu (see Section 3.22, “Counterflow leak test (2)”).

For a more precise description of the counterflow leak test mode, see Section 3.23, “Counterflow leak test (3)”.

## 3.22 Counterflow leak test (2)

IP: 192.168.140.131 Status: Pumping
29.03.2023 14:35:45

Pressure and Timer Limit Values		
Scrollpump ON when p1 >	1E0 mbar	Reset
Scrollpump OFF when p1 <	8E-2 mbar	Reset
Turbopump ON when p1 <	3E0 mbar	Reset
Heating ON when p3 <	1E-5 mbar	Reset
Heating OFF when p3 >	1E-4 mbar	Reset
Heating time	1800 min	Reset
Leaktest enable when p3 <	9E-5 mbar	Reset
RGA enable when p3 <	1E-6 mbar	Reset
Scrollpump timer error when V3 open	60 min	Reset
Turbopump timer error when V3 open	60 min	Reset

**Pressure Time Diagram**

**Zoom Diagram**

**Counter Flow Leaktest**

**Software Info**

**Change Limit Values**

**Back to Main**

If pressure p3 is too high to switch on the leak detector (by default p3 must be  $< 9 \times 10^{-5}$  mbar), the “Counter Flow Leaktest” button appears in the menu.

Pressing this button switches back to the main visualization and leads to the closing of V3 and the opening of V2 (see Section 3.23, “Counterflow leak test (3)”).

### 3.23 Counterflow leak test (3)

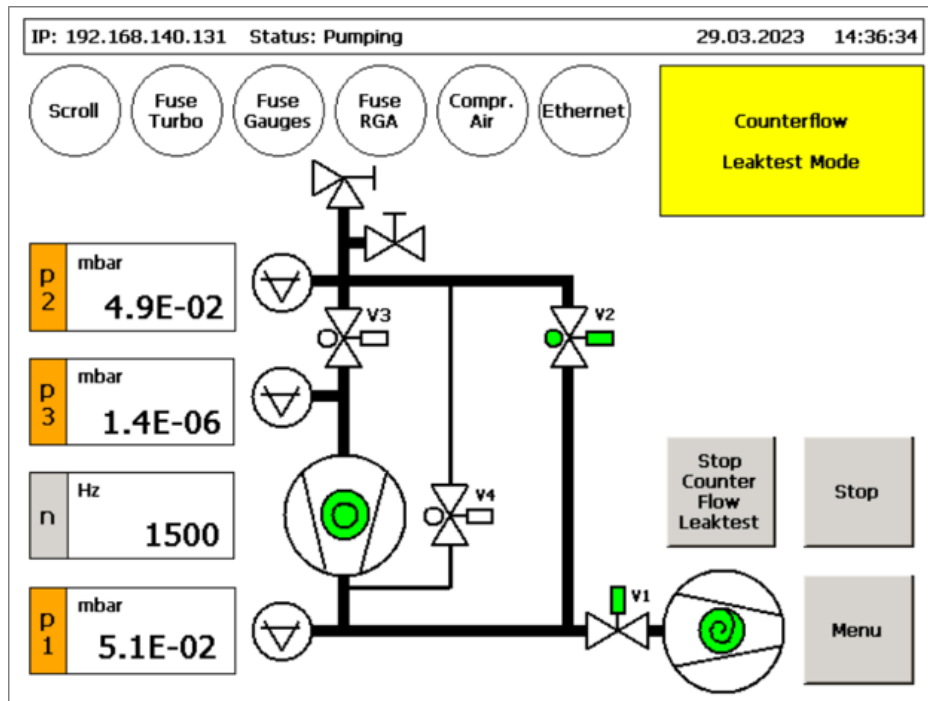

The counterflow leak test is indicated by the “Counterflow Leaktest Mode” window.

This method is performed by closing V3 and opening V2 instead. This leads to a low pressure p3 in the section between the leak detector and V3.

In case of a leak, the helium now flows in the reverse direction through V2 and then through the turbo pump and is detected by the leak detector from the backside.

Pressing the “Stop Counter Flow Leaktest” button switches the pump cart back to normal pumping operation, which means the opening of V3 and the closing of V2 (see Section 3.21, “Counterflow leak test (1)”).

---

## 4 Malfunctions and error handling

The following instructions provide information on troubleshooting errors that can occur when operating the pump cart.

Errors that are not directly indicated on the pump cart display:

- **Pump cart is off and does not turn on**  
Power supply and pump cart main fuse should be checked (see Section 1.2, “Preconditions for operation”).
- **Pump cart display shows everything in red**  
Cable and connection between pump cart computer and PLC terminals should be checked

Error indicators that are shown on the display can be displayed in grey or red, which have different meanings:

- **Grey: No serious error**  
The pump cart can be operated normally, only an additional function may not be available.
- **Red: Serious error**  
The pump cart stops and cannot be operated until the problem has been solved.

A serious error does not mean that it must be difficult to fix; it just means that something important to the operation of the pump cart is not working (for example, missing compressed air).

If an error occurs that cannot be solved with the help of this troubleshooting sections, contact the Vacuum group.

## 4.1 No Ethernet connection

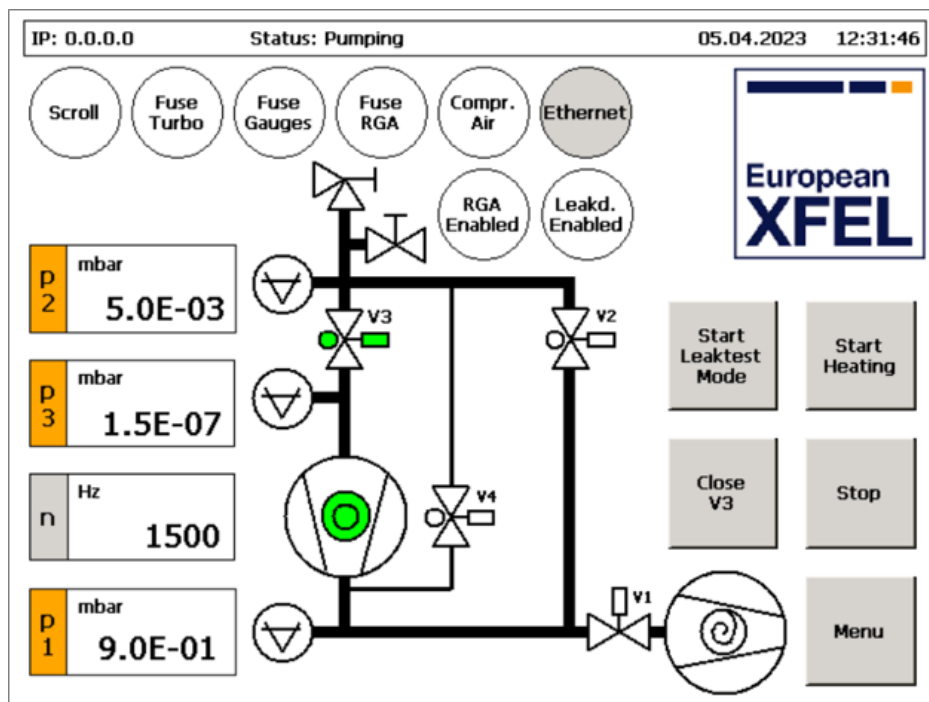

The grey “Ethernet” indicator shows that there is an error concerning the Ethernet connection.

In this case, the IP number 0.0.0.0 is also shown in the status bar.

Possible reasons:

- Loose Ethernet cable to the Wi-Fi bridge
- Loose Wi-Fi bridge power supply cable

The Ethernet connection is only important for remote control of the pump cart; therefore, it is not a relevant error and has no influence of the function of the pump cart.

## 4.2 No compressed air

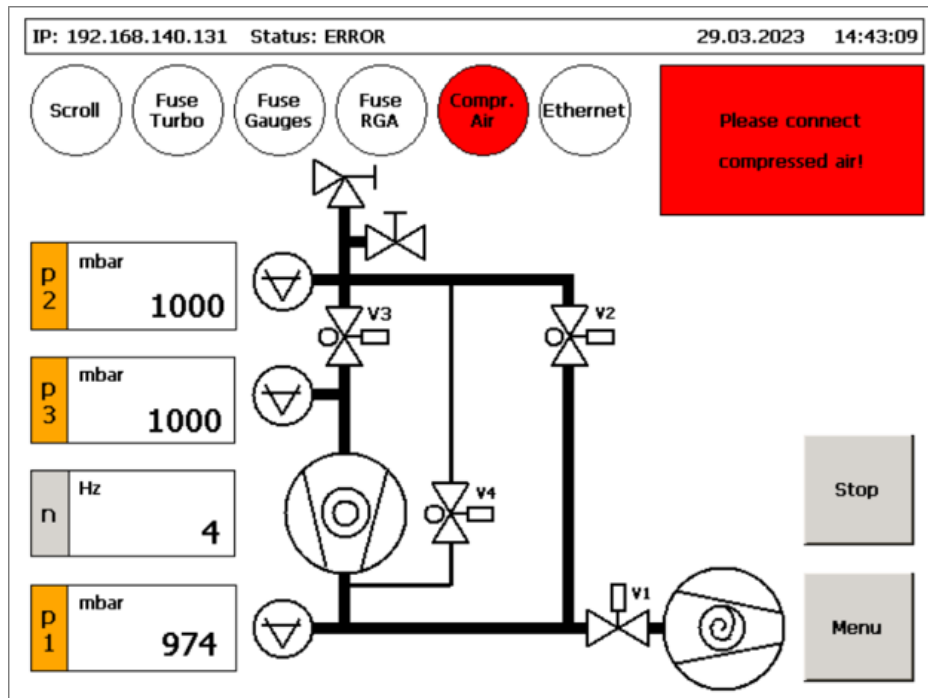

In this case, the pump cart cannot be started.

Possible reasons:

- There is no compressed air connection.
- Compressed air pressure is too low.
- Compressed air switch of the pump cart is not correctly adjusted or broken.



## 4.3 Turbo pump fuse error

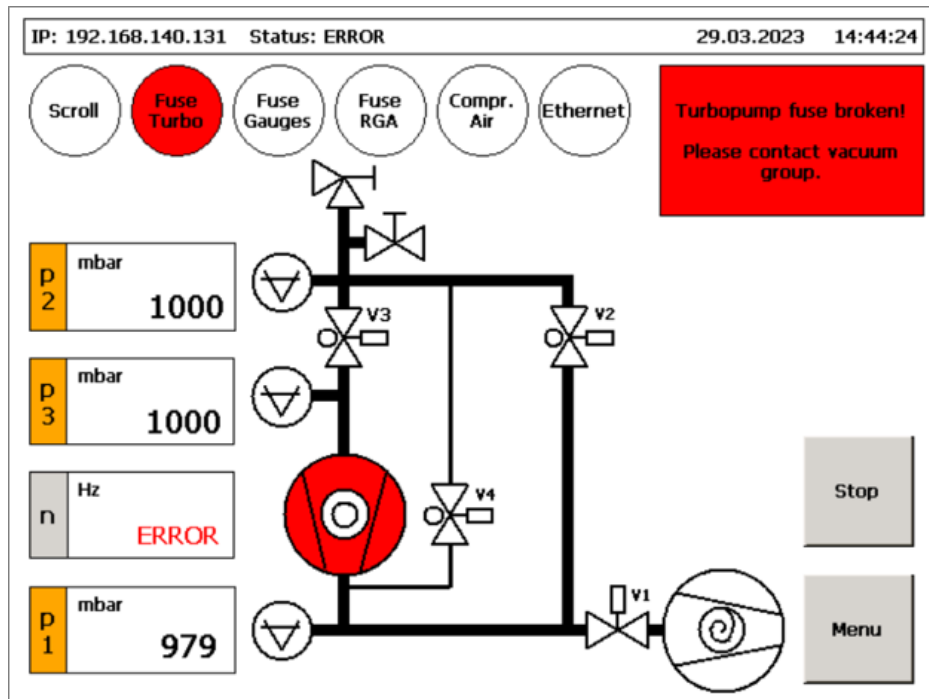

The turbo pump fuse (6,3A) is broken and must be replaced.

The fuse for the turbo pump is located on the back side of the pump cart control box (see Section 1.2, "Preconditions for operation").

## 4.4 Gauge fuse error

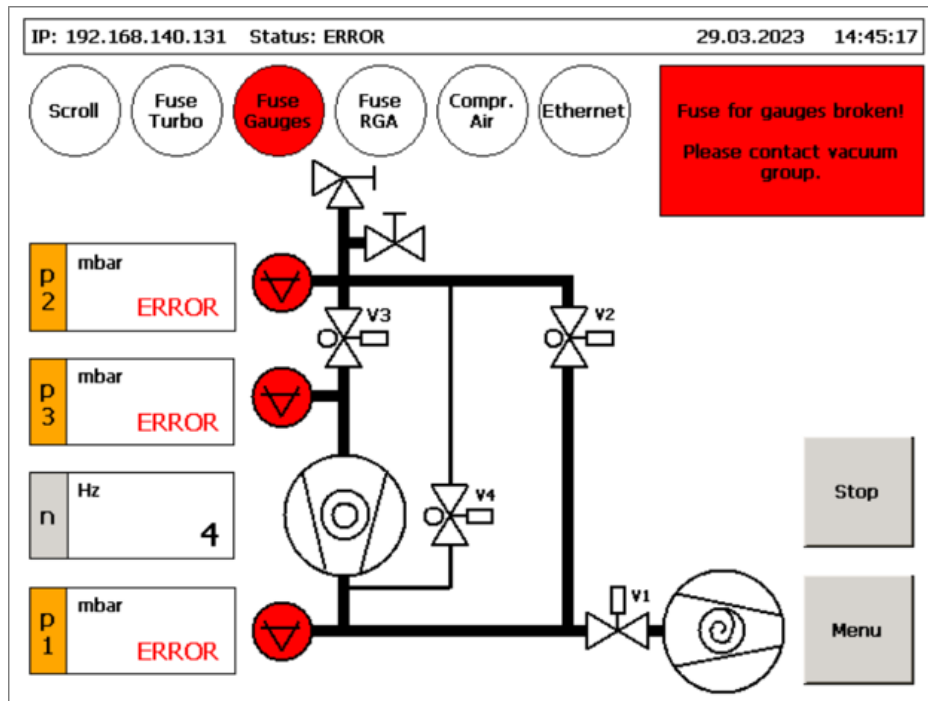

The fuse for the three gauges (800 mA) is broken and must be replaced.

The fuse for the gauges is located on the back side of the pump cart control box (see Section 1.2, "Preconditions for operation").

## 4.5 RGA fuse error

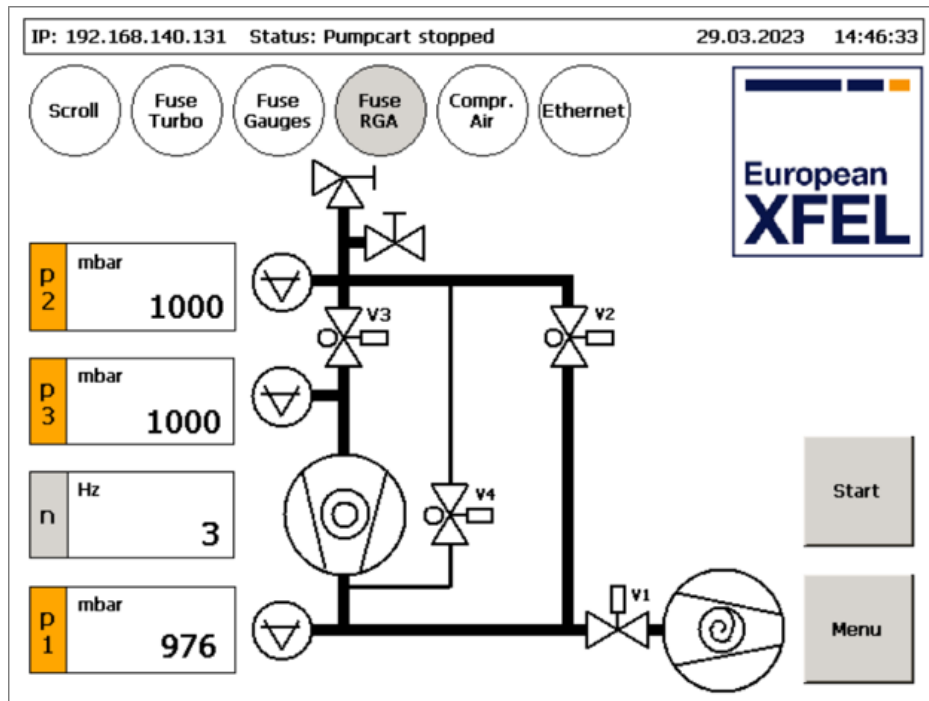

The RGA is an optional device. If you do not want to use an RGA, this error can be ignored and the pump cart can be used as usual.

If you want to use an RGA, the RGA fuse (1.6 A) must be replaced.

The fuse for the RGA is located on the back side of the pump cart control box (see Section 1.2, "Preconditions for operation").

## 4.6 Valve error

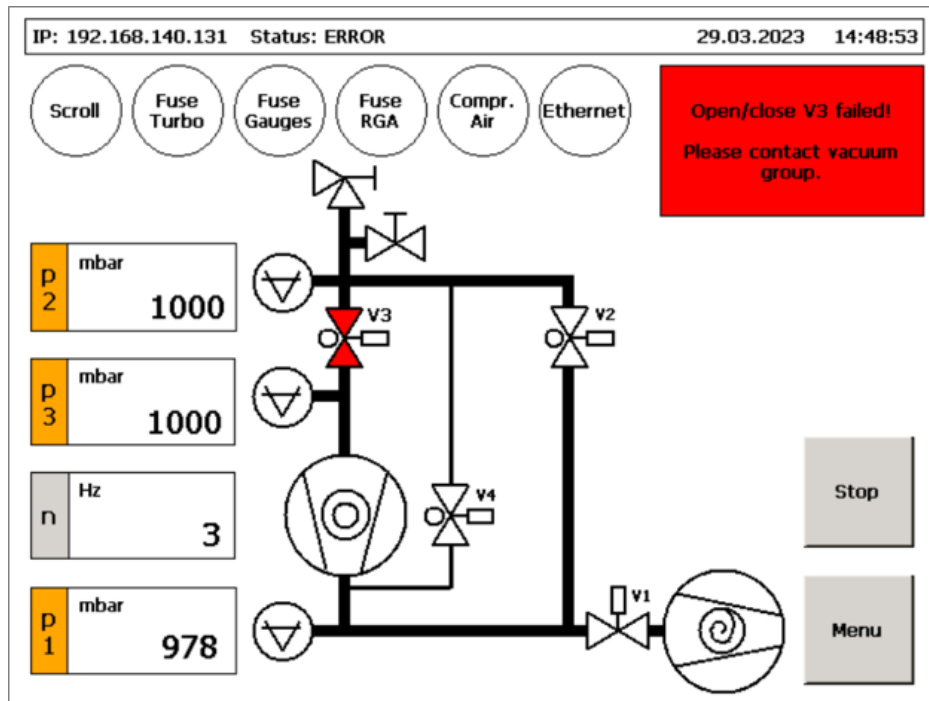

This error can occur for valves V2, V3, and V4. V1 has no end switch, so this error message does not exist for V1.

Possible reasons:

- Broken valve
- Broken or loose power connection to the valve
- Broken valve end switch

## 4.7 Scroll pump has no power

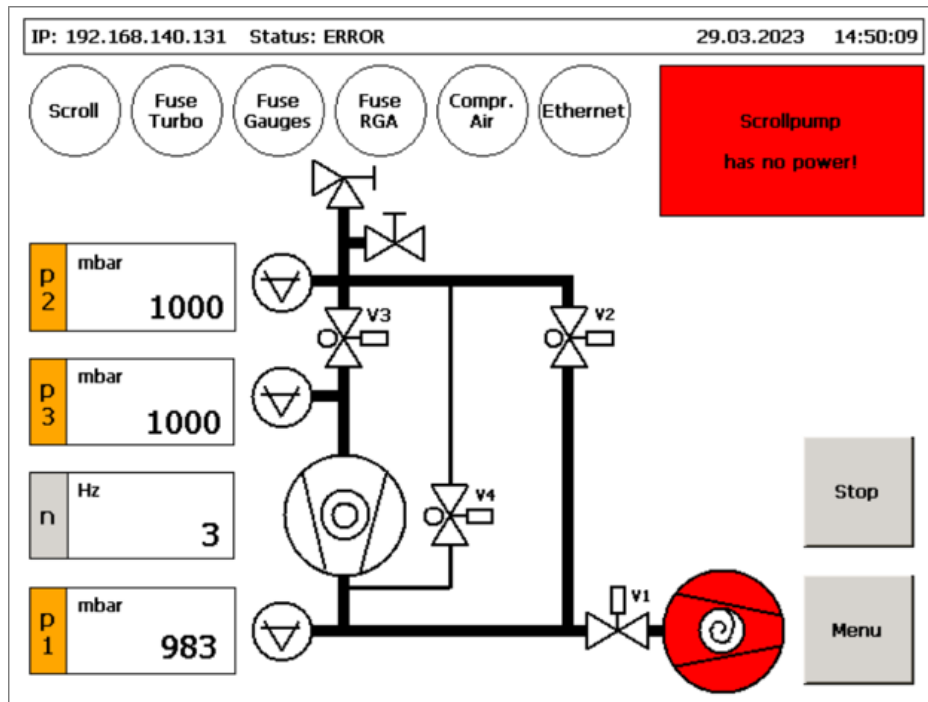

This error occurs if there is a problem with the power supply or control of the scroll pump.

Possible reasons:

- Broken or loose 230 V power cable on the scroll pump
- Broken or loose SUB-D scroll pump control cable

## 4.8 Turbo pump general error

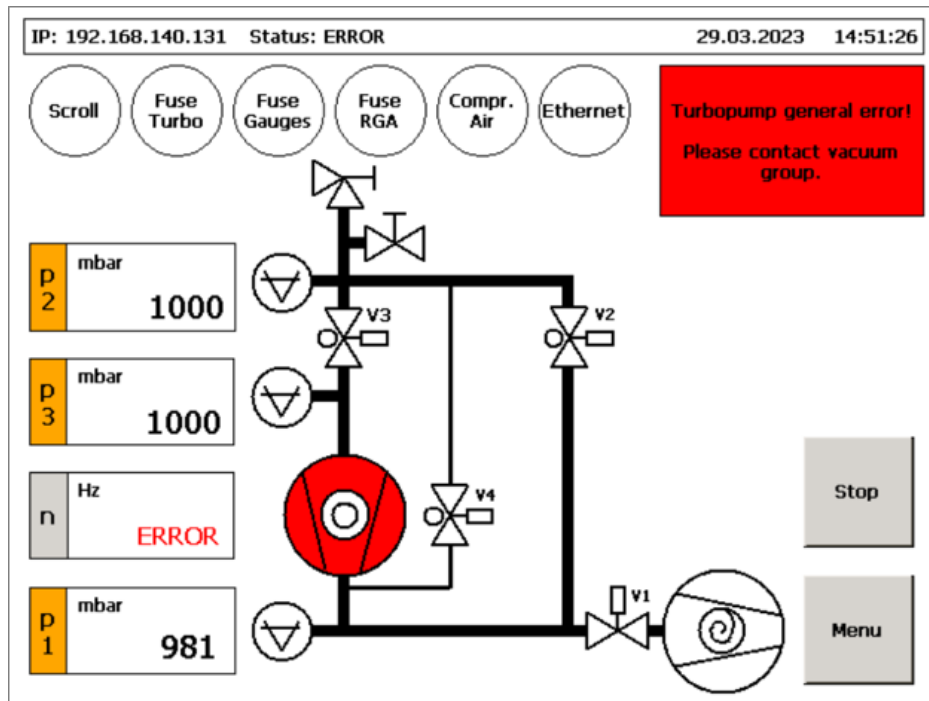

This can be any error of the turbo pump (for example, overheating or wrong rotation speed).

To identify the error, the turbo pump error memory must be read out.

## 4.9 Scroll pump timer error

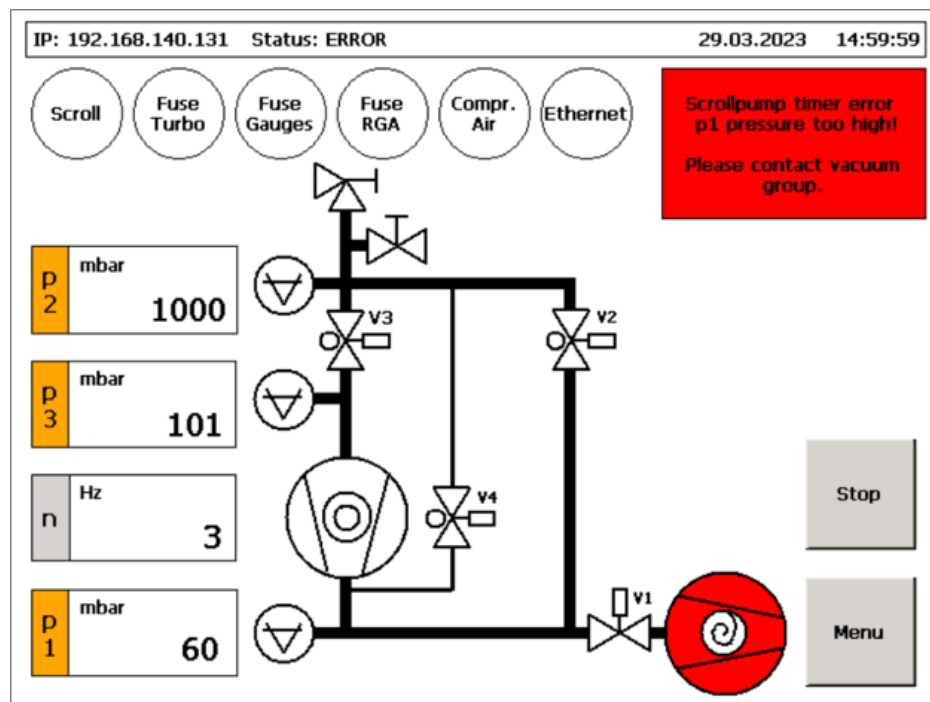

If a certain pressure level is not reached after a certain time, the pump cart stops and all valves close. An error window occurs with the message “timer error”.

In this case, the pressure p1 is not low enough after an expected time.

Possible reasons:

- Leak in the vacuum system
- Faulty scroll pump
- Very big vacuum system

In this particular case, the reason for a long pumping time is due to a very big vacuum system or a system with low conductance. The parameter “Scrollpump timer error when V3 open” in the menu can be changed.

## 4.10 Turbo pump timer error

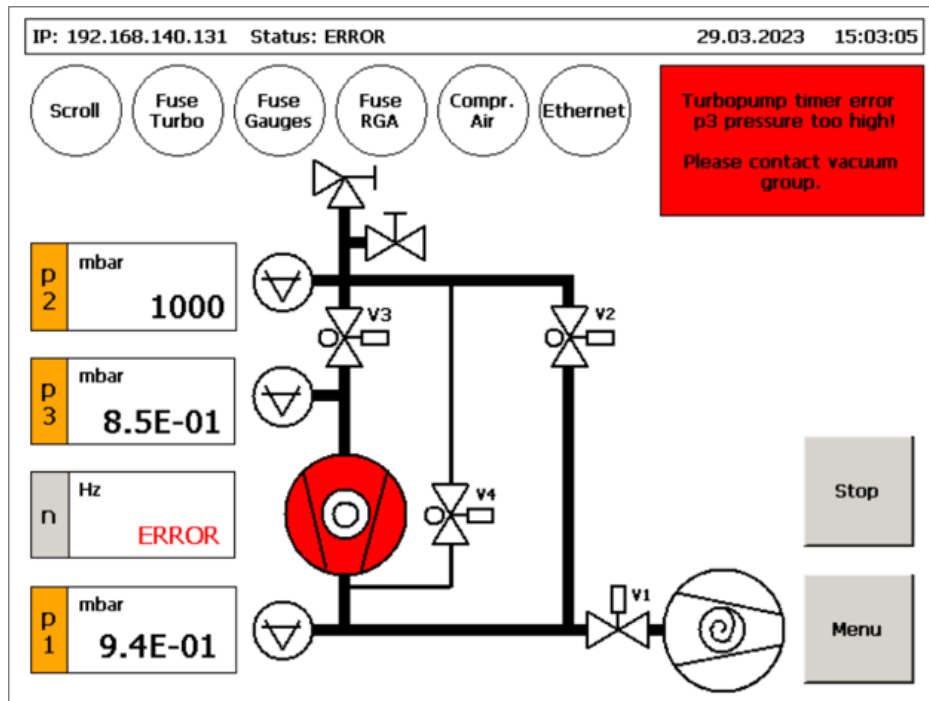

If a certain pressure level is not reached after a certain time, the pump cart stops and all valves close. An error window occurs with the message “timer error”.

In this case, the pressure p3 is not low enough after an expected time.

Possible reasons:

- Leak in the vacuum system
- Faulty turbo pump
- Very big vacuum system

In this particular case, the reason for a long pumping time is due to a very big vacuum system or a system with a low conductance. The parameter “Turbo pump timer error when V3 open” in the menu can be changed.



## 4.11 Pressure p2 too low for venting

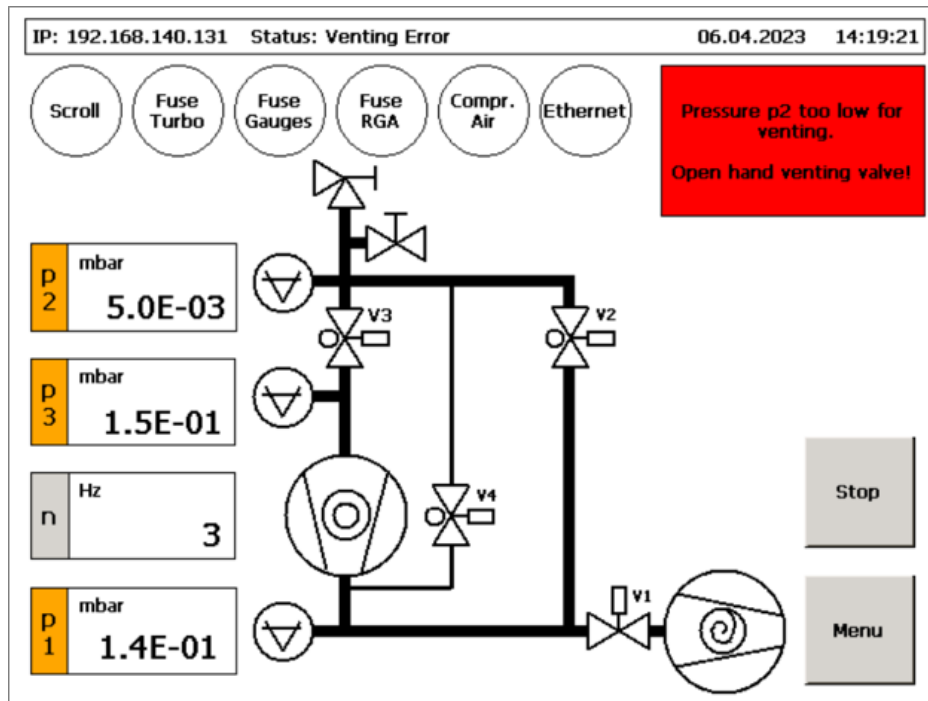

This error message appears if the bottom part of the pump cart should be vented and the hand venting valve is not open.

**NOTE:** For venting, the hand venting valve must be open!

---

# 5 Remote operation per Ethernet

The pump cart can be remotely controlled and monitored via Ethernet if it is registered in the network, which is shown in the status bar (see Chapter 2, “Preconditions for operation”).

## 0.0.0.0

No Wi-Fi connection is available.

## 168.XXX.XXX.XXX

There is a connection between the pump cart PLC and the Wi-Fi bridge but no connection to the Ethernet.

## 192.168.140.XXX

The Ethernet connection is working.

No extra software is required for remote operation. It can be connected to the pump cart directly via the browser.

The link to the pump cart GUI looks like this:

[http://192.168.140.52/Tc3PlcHmiWeb/Port\\_851/Visu/webvisu.htm](http://192.168.140.52/Tc3PlcHmiWeb/Port_851/Visu/webvisu.htm)

↑

Pump cart IP number

It can look this for the example of the pump cart with the alias name Gandalf:

[http://gandalf/Tc3PlcHmiWeb/Port\\_851/Visu/webvisu.htm](http://gandalf/Tc3PlcHmiWeb/Port_851/Visu/webvisu.htm)

↑

Pump cart alias name

## 6 Heating

In heating mode (see Section 3.8, “Heating mode”), the pump cart provides a 24 V release signal to an external heating distributor that can be connected and controlled by the pump cart. Furthermore, the heating sleeve on the turbo pump is heated up.

**CAUTION:** Be careful. The heating sleeve gets hot and should not be touched!

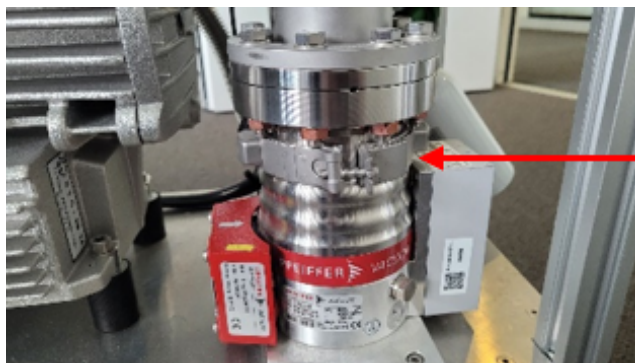

Heating sleeve



Heating connector to connect with the heating controller

# 7 Data logger

To save pressure data in a CSV file (see Section 3.19, “Diagram – Data logger (1)”), a USB stick must be connected to the USB port in front of the pump cart.

The pressure data is stored directly in the main folder of the USB stick when the data logger is started.

The name of the CSV file is of this format:

yyyy-mm-dd\_hh-mm-ss\_interval\_pumpcartname



---

## 8 Leak detection general description

The pump cart is optionally equipped with a leak detector, which includes the following components:

- Leak detector control box
- Leak detector display
- Leak detector sensor
- Calibrated test leak

The leak detector filament can be switched on only when the vacuum is low enough ( $p_3 < 9 \times 10^{-5}$  mbar); otherwise, the filament of the leak detector can be damaged.

The leak detector can be checked and calibrated with the test leak.

**NOTE:** This chapter contains basic instructions on how to operate the leak detector. For more detailed operating instructions, refer to the Pfeiffer Vacuum operating instructions.

---

## 8.1 Using the leak detector

The leak detector main switch is located directly on the red leak detector control box. It switches on the control box and the leak detector display.

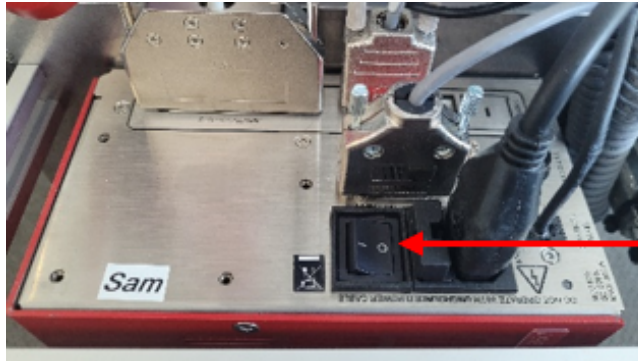

Leak detector main switch



Home button

Start button

An acoustic signal with a leak rate–depending frequency can be switched on.



Switch and potentiometer for Leak rate sound

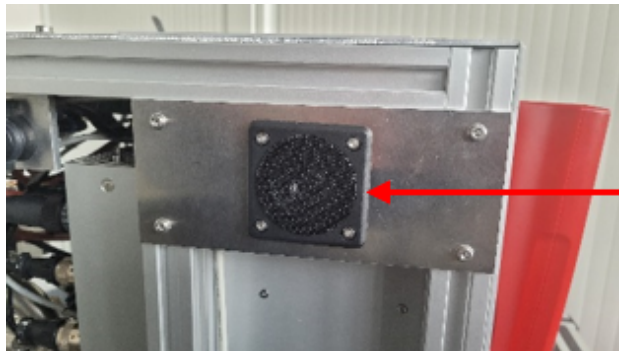

Speaker for leak rate sound

## 8.2 Checking and calibrating the leak detector

The calibration and verification of the leak detector is carried out with the test leak, which releases a small, defined amount of helium when the needle valve is opened. The defined leak rate and date are written on a sticker on the test leak. This data must be entered in the leak detector menu for calibration.

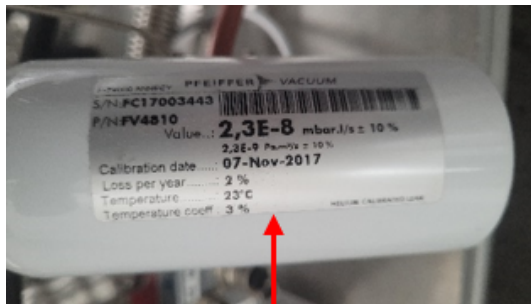
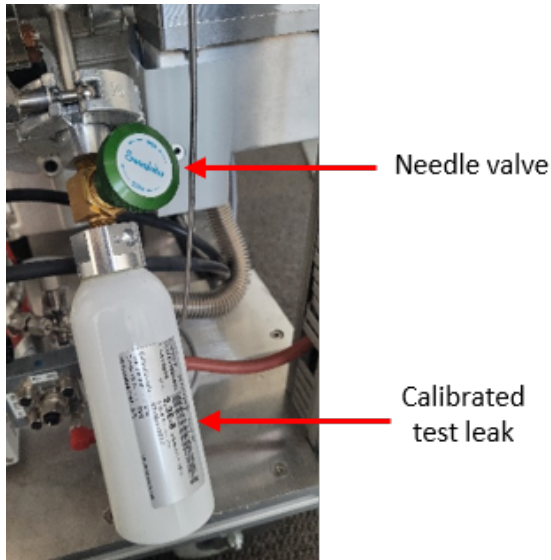

Sticker with  
leak rate and date



---

## 9 Leak detector display

The leak detector display shows the status of the leak detector, as well as the current leak rate, which can also be displayed as a graph.

---

### 9.1 Leak detector display after switching on the leak detector

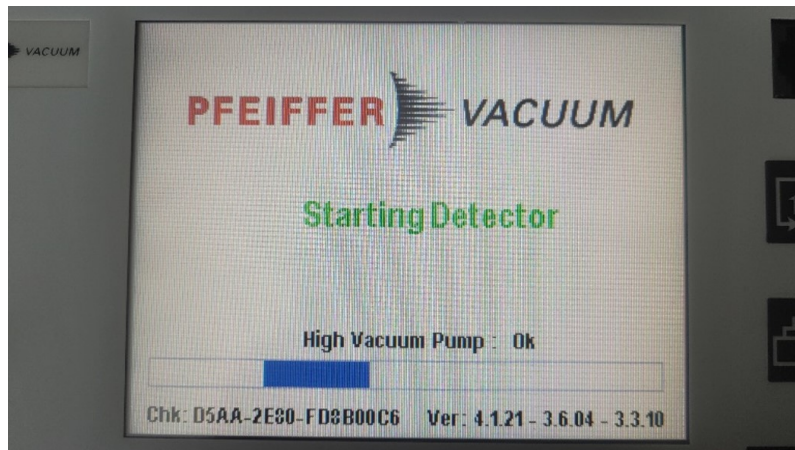

When the leak detector is started it takes some time for the startup.

---

### 9.2 Leak detector display after startup of the leak detector

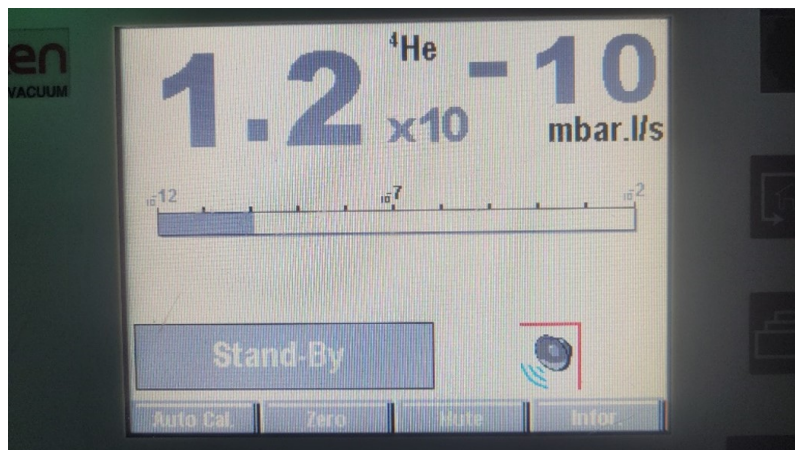

After startup, the leak detector is in the "Stand-By" mode and the display looks like this. Pressing the "Start", button switches the leak detector to "Measuring" mode.

### 9.3 Measuring mode (1)

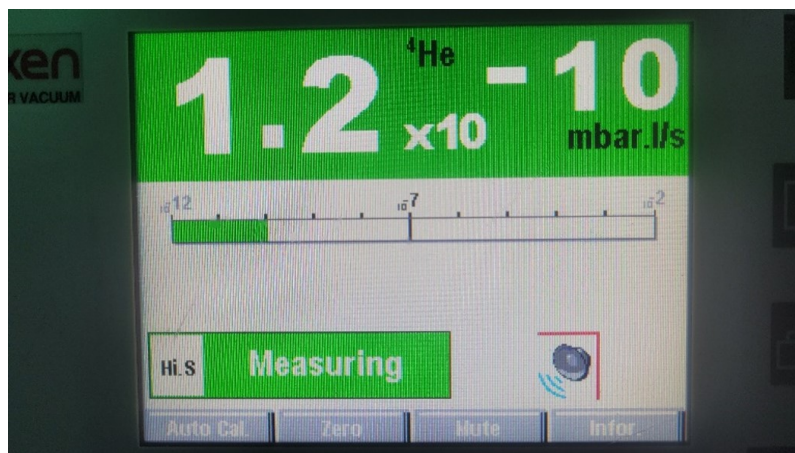

The leak rate is shown in green or red color.

**Green:** The leak rate is below  $1 \times 10^{-8}$  mbarL/s.

### 9.4 Measuring mode (2)

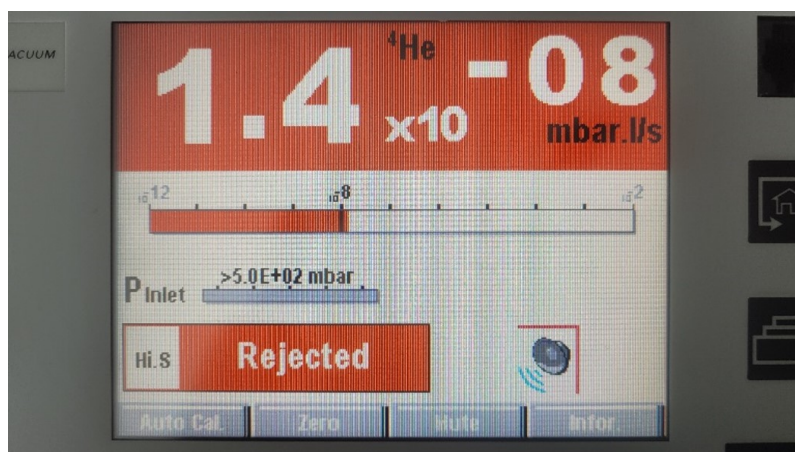

**Red:** The leak rate is above  $1 \times 10^{-8}$  mbarL/s.

---

## 9.5 Diagram mode

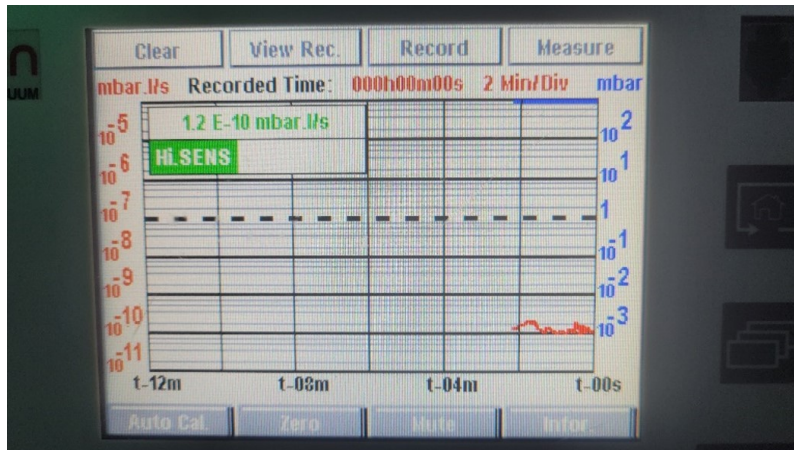

The screen view can be switched to diagram mode by pressing the “Home” button.

---

## 9.6 Filament interlock

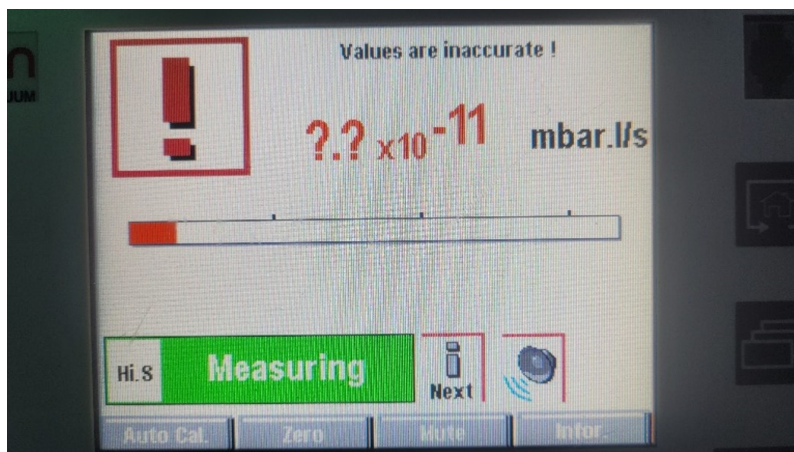

This view means that the leak detector filament is not switched on and interlocked because pressure  $p_3$  is too high ( $> 9 \times 10^{-5}$  mbar).

The leak detector interlock has the function of protecting the filament. It turns off the leak detector when the pressure rises. When the pressure is too high, it cannot be turned on at all.

**CAUTION:** The filament interlock is only intended for emergencies. THE LEAK DETECTOR MUST BE SWITCHED OFF BEFORE THE PUMP CART IS VENTED!

# 10 Leak detector remote control

The pump cart is optionally equipped with a remote control for the leak detector. This makes it possible to operate the leak detector at a distance of up to 100 m from the pump cart via a Bluetooth connection. This option is very useful for leak-testing large vacuum systems.

The remote control sticks to the pump cart with magnets and can be removed when the charging cable is removed.

The corresponding Bluetooth dongle of the pump cart with which you have to connect is already stored in the menu. It may be that this has to be selected again.

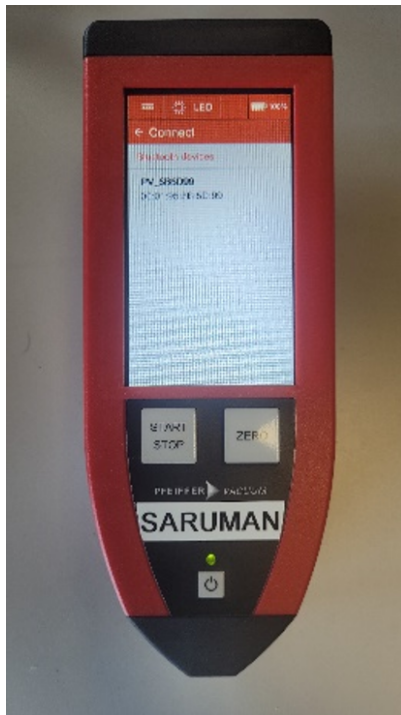

**Figure 10.1:** Remote control menu with Bluetooth dongle address



**Figure 10.2:** Remote control display in measuring mode